

International Technical Exhibition of Medical Imaging 2018

ITEM 2018

Guide for Exhibitors



Sponsored by: Japan Radiology Congress (JRC)



**Organized by: Japan Medical Imaging and
Radiological Systems Industries Association**



CONTENTS

1. OUTLINE OF THE ACADEMIC CONGRESSES	2
2. OUTLINE OF THE INTERNATIONAL TECHNICAL EXHIBITION OF MEDICAL IMAGING 2018	3
3. JOINT EVENTS WITH JRC2018	4
4. ACCESS TO THE SITE	5
5. ENTRY TO THE EXHIBITION SITE	6
6. HOURS OF SITE USE AND OVERTIME WORK	7
7. LOAD-IN/LOAD-OUT, AND INSTALLATION WORK	8
8. ABOUT A LOAD-IN/LOAD-OUT STANDBY PLACE	8
9. NOTES ON EXHIBIT MANAGEMENT FOR ALL EXHIBITORS	9
10. NOTES ON EXHIBIT MANAGEMENT IN SPACE BOOTHS L AND M	12
11. NOTES ON DECORATION FOR SPACE BOOTHS L AND M	12
12. ABOUT TWO-STORY STRUCTURE IN SPACE BOOTHS L AND M	15
13. FIGURES FOR SPACE BOOTHS L AND M SHOWING CAUTIONS	17
14. NOTES ON DECORATING WORK IN BOOTHS WITH BASIC FITTINGS	26
15. DRAWING OF BOOTH WITH BASIC FITTINGS	29
16. ELECTRICITY	31
17. TELEPHONES AND COMMUNICATION LINES	32
18. DEMONSTRATIONS INVOLVING TRANSMISSIONS	32
19. CONSUMPTION OF FOOD AND DRINK	32
20. CLEANING	32
21. FIRE AND DISASTER PREVENTION	33
22. RECOMMENDED CONTRACT COMPANIES	33
23. ABOUT OUR RESPONSIBILITY AND YOUR EXPENSES	34
24. ABOUT COMPLIANCE WITH LAWS AND REGULATIONS	35
25. MISCELLANEOUS	35

26. EXHIBITION OF PRODUCTS NOT APPROVED UNDER THE ACT ON THE PHARMACEUTICALS, MEDICAL DEVICES, ETC.	36
27. WHERE TO INQUIRY AND SUBMIT DOCUMENTS (RELATED TO EXHIBITION ANDREQUIRED)	40
FORM 9-1, 9-2	42
FORM 11, 12, 13, 14	44
*FORM 1, 2, 3, 4, 6, 7 AND 8	SEPARATE EXCEL FILE

The International Technical Exhibition of Medical Imaging 2018

The International Technical Exhibition of Medical Imaging (ITEM) 2018, an exhibition of medical imaging equipments will be held concurrently with the Annual Meeting of Japan Radiology Congress (JRC) 2018 in the *Pacifico* Yokohama Exhibition Hall with the following details.

The Exhibition Committee of the Japan Industries Association of Radiological Systems (JIRA) has determined the operational essentials described herein. Your cooperation in observance of them would be highly appreciated in order to achieve smooth operation and a satisfactory outcome of the exhibition.

Sponsor: Japan Radiology Congress (JRC)



Kandasurugadai Bldg.7F, 3-8, Kandaogawamachi,
Chiyoda-ku, Tokyo 101-0052, Japan
Phone: 81-3-3518-6111 Facsimile: 81-3-3518-6139

Operation: Japan Medical Imaging and
Radiological Systems Industries Association (JIRA)



Sumitomo Fudosan Iidabashi Bldg. No.2 6F, 2-2-23, Koraku,
Bunkyo-ku, Tokyo 112-0004, Japan
Phone: 81-3-3816-3450 Facsimile: 81-3-3818-8920

1. Outline of the Academic congresses

Main Theme: Innovative Science and Humanism in Radiology

- **The 77th Annual Meeting of the Japan Radiological Society (JRS)**

President: Yutaka Imai (Tokai University)

Date: April 12 (Thu.) to April 15 (Sun.), 2018

Site: Conference Center and Annex Hall, *Pacifico* Yokohama

- **The 74nd Annual Scientific Congress of the Japanese Society of Radiological Technology (JSRT)**

President: Shigeo Nishiki (Tenri Hospital)

Date: April 12 (Thu.) to April 15 (Sun.), 2018

Site: Conference Center and Annex Hall, *Pacifico* Yokohama

- **The 115th Scientific Meeting of the Japan Society of Medical Physics (JSMP)**

President: Hiroshi Oguchi (Nagoya University)

Date: April 12 (Thu.) to April 15 (Sun.), 2018

Site: Conference Center, *Pacifico* Yokohama

2. Outline of the International Technical Exhibition of Medical Imaging 2018 (ITEM2018)

- **Exhibition Date:** April 13 (Fri.) to April 15 (Sun.), 2018
- **Site:** Exhibition Hall [Halls A(a part)+ B + C + D]
at *Pacifico* Yokohama, Total 18,400 m²
(Address: 1-1-1 Minato Mirai, Nishi-ku, Yokohama, 220-0012, Japan)
- **Load-in:** April 9 (Mon.) to April 12 (Thu.), 2018
- **Load-out:** April 15 (Sun.) to April 16 (Mon.), 2018
- **Opening Ceremony:** 9:30 – 10:00 on April 13 (Fri.), 2018
In front of the main entrance to the exhibition halls,
Pacifico Yokohama
- **Exhibition hours:** April 13 (Fri.): 10:00 (following the opening ceremony) – 17:00
April 14 (Sat.): 9:30 – 17:00
April 15 (Sun.): 9:30 – 15:00
- **Exhibitors and exhibition space**
 - Number of exhibitors: 161
 - Total exhibition space: 8,903 m²
 - Exhibition booths with basic fittings:
 - Booth A 3.0 m (W) × 3.0 m (D) x 89 (Small Unit) / 50 exhibitors
(Joint exhibition: 2 pairs)
 - Booth B 3.0 m (W) × 2.0 m (D) x 86 (Small Unit) / 59 exhibitors
(Joint exhibition: 6 pairs)
 - Booth C for related medical societies and research institutions
2.0 m (W) × 1.5 m (D) x 2 (Small Unit) / 2 exhibitor
 - Space (M)
 - 40 m² x 10 booths/11 exhibitors (Joint exhibition: 1 pair)
 - 60 m² x 6 booths / 6 exhibitors
 - 80 m² x 6 booths / 6 exhibitors
 - 100 m² x 3 booths / 3 exhibitors
 - 120 m² x 3 booths / 3 exhibitors
 - 140 m² x 2 booths / 3 exhibitors (Joint exhibition: 1 pair)
 - 160 m² x 1 booths / 2 exhibitors (Joint exhibition: 1 pair)
 - 240 m² x 1 booth / 1 exhibitor
 - Space (L)
 - 500 m² x 3 booths / 4 exhibitors (Joint exhibition: 1 pair)
 - 600 m² x 3 booths / 5 exhibitors (Joint exhibition: 1 pair)
 - 700 m² x 1 booth / 1 exhibitors
 - 1000 m² x 1 booth / 4 exhibitor (Joint exhibition: 1 pair)
 - Medical examination vehicle exhibition 1 exhibitor

3. Joint Events with JRC2018

- **Joint Opening Ceremony: 13:00 - 13:50, April 13 (Fri.), 2018**
Conference Center of *Pacifico* Yokohama, Main Hall
Each president greeting, Keynote speech
- **Joint Special Lecture**
April 13 (Fri.), 2018, 14:20 – 15:00
Conference Center of *Pacifico* Yokohama, Main Hall
Moderator : Yutaka Imai (Tokai Univ.)
Koichi Tanaka (Nobel laureate, SHIMADZU CORPORATION)
- **Joint education session**
April 13 (Fri.), 2018, 9:50 – 11:50
Conference Center of *Pacifico* Yokohama, Room302
“Diagnostic and Therapeutic Indications of Prostate Cancer”
- **Joint Symposiums**
 - 1) April 13 (Fri.), 2018, 15:10 – 17:10
Conference Center of *Pacifico* Yokohama, Main Hall
"Management for Radiation Dose Reduction in Clinical Practice"
 - 2) April 14 (Sat.), 2018, 9:00 – 11:30
Conference Center of *Pacifico* Yokohama, National Convention Hall
"Establishing fundamental knowledge for the clinic ! : An invitation to preclinical research"
 - 3) April 14 (Sat.), 2018, 13:00 – 15:00
Conference Center of *Pacifico* Yokohama, Main Hall
"Current status of Radiomics research in radiology"
- **Joint Reception for JRC Members: 18:15 – 19:30, April 13 (Fri.), 2018**
Queen’s Grand Ballroom, Pan Pacific Yokohama Bay Hotel Tokyu
- **Joint Awards Ceremony and Joint Closing Ceremony:**
15:00 – 16:15, April 15 (Sun.), 2018
Conference Center of *Pacifico* Yokohama, Main Hall

4. Access to the Site

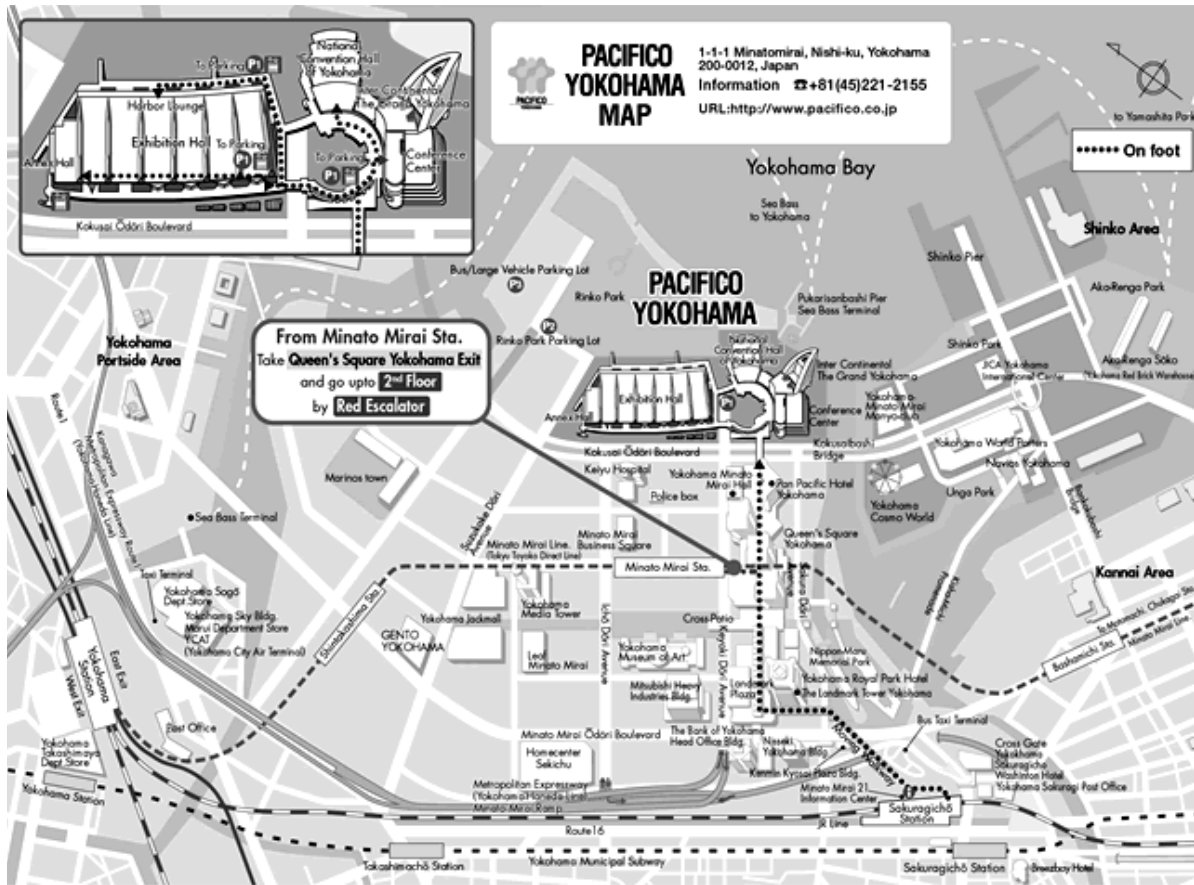

Traffic Information

By Train	Station	Line	Time	Transfer	Time	Notes	
By train	Shibuya Sta.	Tokyu Toyoko Line : Limited Express (Direct link to Minato Mirai Line)	30min.	Minato Mirai Line	3min.	on foot	
	Shinjuku Sta.	JR Shonan Shinjuku Line	28min.	Minato Mirai Line	3min.	Connecting from Tokyu Toyoko Line	
By train & Shinkansen	Tokyo Sta.	JR Tokaido Line	25min.	Yokohama Sta.	by Taxi	7min.	
	Shinagawa Sta.	Keikyū Express : Limited Express	15min.	Yokohama Sta.	by Taxi	7min.	
	Shin Yokohama Sta.	JR Yokohama Line	3min. to Kiuna Sta. / 8min. Connecting to Minato Mirai Line (link to Minato Mirai Sta.)	3min.	JR Keihin-Tohoku Line	3min.	on foot
		JR Yokohama Line	15min. (Change to Keihin-Tohoku Line at Higashi-Nagawa Sta.)	15min.	Sakuragichō Sta.	by Bus	7min.
By Air	Narita Airport	JR Narita Express	90min.	Yokohama Sta.	Minato Mirai Line	3min.	Connecting from Tokyu Toyoko Line
		Airport Limousine Bus	90min.	Yokohama Sta.	Minato Mirai Line	3min.	Connecting from Tokyu Toyoko Line
	Haneda Airport	Keikyū Express	24min.	YCAT Yokohama City Air Terminal Yokohama St. East.	by Taxi	7min.	

Driving To Pacifico

From Tokyo	Route	Time	Notes
Metropolitan Expressway	Toward Yokohama Park, Yokohane Route	Minato Mirai Ramp, 3min.	
	Toward Yokohama (over Bay bridge), Wangan Route	Minato Mirai Ramp, 3min.	
From Kansei or Chubu	Tomei Expressway Yokohama Machida IC	Hodogaya Bypass 20min → Kariba IC → Toward Yokohama, Metropolitan Expressway, Kariba Route, 10min → Minato Mirai Ramp, 3min	

Parking Lot

Parking Lot	Capacity	Hours	Rates	Discounts
Minato Mirai Public Parking Lot ☎045-221-1301	Capacity: 1,200 (Standard-sized car)	Open 24 hours	Rates: ¥260/30min.	*Weekday Discount : 8:00~23:00 ¥1,300 for max *Late Night Discount : 0:00~ 6:00 half-rate
Rinko Park Parking Lot ☎045-221-2175	Capacity: 100 (Standard-sized car)	10:00~21:00	Rates: ¥500/hour	
Bus/Large Vehicle Parking Lot ☎045-221-1302	Capacity: 40 (Bus, Large Vehicle)	Open 24 hours (Loading and unloading: 7:00~22:00)	Rates: ¥500/30min.	*Late Night Discount : 22:00~7:00 half-rate

Printed on recycled paper. August, 2006

5. Entry to the exhibition site

(a) Entry of exhibitors and persons concerned

- (i) Exhibitors and persons concerned shall wear an Exhibitor's Card when entering the site. Persons without an Exhibitor's Card shall not be allowed to enter the site during the exhibition. Please obtain your Exhibitor's Card by contacting the exhibitor concerned. No Temporary Entrance Cards shall be issued for this year's exhibition.
- (ii) Persons in charge of load-in/load-out and installation work shall put on an Exhibitor's Card or Workman's Card when entering the site. **Please be sure to wear the card even during such load-in/load-out or installation work.**

(b) Obtaining Exhibitor's Cards and Workman's Cards

- (i) Free Exhibitor's Cards shall be provided in the amounts given below.
 - Booth A with basic fittings 10 cards per unit
 - Booth B with basic fittings 10 cards per unit
 - Booth without fittings 1 card per 2 m² (rounded up)
- (ii) Free Workman's Cards shall be provided in the amounts given below.
 - Booth A with basic fittings 10 cards per unit
 - Booth B with basic fittings 10 cards per unit
 - Booth without fittings 1 card per 3 m² (rounded up)
- (iii) Please apply for additionally paid Exhibitor's Cards and Workman's Cards by using the **Name Card Application Form** by **Friday, February 16, 2018**.
 - Exhibitor's Card ¥324 per card (tax included)
 - Workman's Card ¥108 per card (tax included)

(c) Entry of visitors

- (i) Visitors shall request a Registration/Entry Card and wear this card when entering the site.
- (ii) Visitors not in possession of a Registration/Entry Card must pay an entry fee of ¥3,000 (¥1,000 for medical students and medical technology students) and receive a Registration/Entry Card before entering the site.

(d) Distribution of Registration/Entry Cards

The base quantity of Registration/Entry Cards (invitation included) distributed is 10 cards per 1 m². These cards are allocated by the organizers for the purpose of improving the performance of the exhibition, so please use them for PR purposes.

If additional quantities of Registration/Entry Cards are required, please apply for them by **Tuesday, January 9, 2018**. However, additional quantity of the cards will be allocated in consideration of various conditions.

(e) Entry of registered members of the societies

Members should wear the society registration cards for entry.

(f) About distribution of an admission ticket

The admission ticket of ITEM is not free of charge. The ticket distributed in advance can be converted into money. If we print or stamp the company's name on the ticket or its envelope, then we violate the fair competition rule. This is because the ticket is regarded as the "premiums" that attracts customers in the business of medical equipment. We are delegated by JRC to distribute the tickets and we must distribute the tickets to customers without printing the company's name on the tickets.

○ **Colors of name cards**

Classification	Meeting /Exhibition	Color of name card or cord
Japan Radiological Society (JRC)	Meeting	Red (cord)
Japanese Society of Radiological Technology (JSRT)	Meeting	Blue (cord)
Japan Society of Medical Physics (JSMP)	Meeting	Light green (cord)
Student member	Meeting	White (cord)
Non member	Meeting	Yellow (card)
Physician	Exhibition	Red (card)
Radiologist (including clinical technologist)	Exhibition	Blue (card)
Healthcare persons except above	Exhibition	Light blue (card)
Educational researcher and student	Exhibition	Green (card)
Exhibitor and persons in the same profession	Exhibition	Orange (card)
Miscellaneous	Exhibition	Black (card)

6. Hours of site use and overtime work

(a) Hours of site use

April 9 (Mon.)	12:00 – 20:00	Load-in/Installation
April 10 (Tue.)	9:00 – 20:00	Load-in/Installation
April 11 (Wed.)	9:00 – 20:00	Load-in/Installation
April 12 (Thu.)	9:00 – 20:00	Load-in/Installation
April 13 (Fri.)	8:00 – 18:00	During exhibition
April 14 (Sat.)	8:30 – 18:00	During exhibition
April 15 (Sun.)	8:30 – 24:00	During exhibition & Dismantle/Load-out
April 16 (Mon.)	6:00 – 11:00	Dismantle/Load-out

(b) Overtime work

Please submit an Overtime Work Notification to the organizer before performing overtime work. The organizer shall charge each company for overtime work for work performed before or after the times shown in the table above.

The charge for overtime work is ¥30,000 per 30 minutes (tax included). This charge shall be divided proportionately when multiple companies apply for overtime work.

7. Load-in/load-out and installation work

(a) Load-in

Decoration materials and exhibits	April 9 (Mon.)	12:00 – 20:00 For booths without basic fittings only.
	April 10 (Tue.), April 11 (Wed.)	9:00 – 20:00
	April 12 (Thu.)	9:00 – 20:00 (17:00~ Cleaning the site.)

Line work and electrical installation are scheduled 9:00 - 12:00 on April 9 (Mon.).

(b) Load-out

Packing materials load-in	April 15 (Sun.)	15:00 – 16:00
Load-out by exhibitors in booths with basic fittings	April 15 (Sun.)	16:00 – 19:30
Load-out by exhibitors in booths without basic fittings	April 15 (Sun.)	16:00 – 24:00
	April 16 (Mon.)	7:00 – 11:00

(c) Procedure for load-in/load-out work

- (i) Details out of the load-in/load-out work plan will be provided at a future date. Please submit **the Notification of the Number of Load-in/Load-out Vehicles by Friday, Feb. 16, 2018.**
- (ii) **The organizer shall determine load-in/load-out work plan in consideration of exhibitors' locations. Your load-in/load-out time requested may be shifted, because the booths near the entrance/exit will be given a high priority.**
- (iii) Costs for load-in/load-out shall be the exhibitors' responsibility.
- (iv) Please station a staff at your booth to enable the trouble-free receipt of items delivered by delivery services. The organizer and exhibition secretariat shall not be able to receive them in exhibitors' stead.
- (v) Please do not leave the transportation vehicle unattended and move away from the site immediately after completion of load-in/load-out work, otherwise they will occupy space of passage and disturb approach the coming load-in/load-out vehicle.

8. About a load-in/load-out standby place

- (a) A Load-In/Load-Out Permit Card will be available through application in advance. Please put up the Card on the front of each load-in/load-out vehicle (including cars for decoration work), go to a load-in/load-out standby place, and follow the instruction given by our staff.
- (b) Even if you have a Load-in/Load-out Permit Card with you, you cannot go to the booth directly. Be sure to go to a vehicle standby place and to follow the instruction given by our staff.
- (c) Please note that overtime parking or overnight parking is not allowed. Load-In/Load-Out Permit Cards will be provided together with the load-in/load-out work plan at a future date.

Parking times (scheduled)

April 9 (Mon.)	7:00 – 22:00
April 10 (Tue.) – April 12 (Thu.)	7:00 – 22:00
April 15 (Sun.)	14:00 – 24:00

The parking times above are tentative at this point. Exhibitors shall be informed of parking times at a future date after these have been determined.

9. Notes on exhibit management for all exhibitors

- (a) Actions that may conflict with the Medical Law and other relevant legislation are prohibited.
- (b) In principle, exhibitors are not allowed to exhibit products that are not approved under the Act on Pharmaceuticals, Medical devices, etc.
To request special permission for such an exhibit, please follow the necessary procedure (**Application for Exhibition/Request for Exhibition**) by Friday, Feb. 16, 2018.
Note, however, that exhibitors are not allowed to perform promotional activities such as distribution of catalogues or pamphlets, videos, or narration.

Exhibitors in booths either with or without basic fittings are requested to produce a booth floor plan showing the locations of exhibits of products that are not approved under the Act on Pharmaceuticals, Medical devices, etc. with the names of such products in red, and to submit it by Friday, Feb. 16, 2018.

***Handling of products not approved under the Act on Securing Quality, Efficiency and Safety of Pharmaceuticals, medical devices, re-generative and cellular therapy products, gene therapy products, and cosmetics (hereafter referred to as “the Act on the Pharmaceuticals, Medical devices, etc.”)**

Please refer to “Exhibition of products not approved under the Act on Pharmaceuticals, Medical devices, etc.” and “Detailed regulations for exhibiting products not approved under the Act on Pharmaceuticals, Medical devices, etc.” Please refer to pages 36 to 39.

“A product that is not approved under the Act on Pharmaceuticals, Medical devices, etc.” means a medical device for which a corporate body permitted to carry out production and sales of medical devices is currently applying to the government agencies concerned in order to gain pharmaceutical approval, but has not yet received such approval.

As stated above, exhibitors are required to follow the necessary procedures to exhibit products that have not yet received pharmaceutical approval. Please ensure that you comply with relevant legislation when dealing with products that have not received pharmaceutical approval, and that these do not conflict with any prohibitions.

Should you have any queries on this matter, please contact the relevant government agencies.

Guidelines for Products That Have Not Received Pharmaceutical Approval (The Japan Federation of Medical Devices Associations)

<http://www.jfmda.gr.jp/information/pdf/gaidorain.pdf>

- (c) About joint exhibit
When you plan the joint exhibit, both you and your partner must be JIRA members, or both you and your partner must be non-JIRA members. If a member and a non-member are combined, then that member must pay the booth fee that is imposed on a non-member.
- (d) Exhibitors are not permitted to transfer or sublet whole or part of the allocated booths to a third person under the regulations of this industry associations.
- (e) **Please make sure not to prominently display company names or logos other than that of the exhibiting company to ensure that it does not give rise to the misunderstanding that (c) above has been violated. If displaying company names or logos other than that of the exhibiting company on the parapet or on walls facing the aisles, please confirm with the Exhibition Committee.**
- (f) Exhibitors are not permitted to introduce or exhibit dangerous articles (including radioactive materials)
- (g) Exhibitors are not permitted to produce foul odors or to perform any activities that

inconvenience other exhibitors.

- (h) Exhibitors' staffs are not permitted to stand in groups in the aisle in front of their own booth, obstructing other exhibitors' booths and the passage of visitors.
- (i) **Exhibitors are not permitted to offer explanations or to distribute informational materials in the aisles. Please make a presentation of exhibits and calling in, or distribute materials such as, handbills, pamphlets, and questionnaires in your own booth.**
- (j) Exhibitors are not permitted to photograph or make video or other recordings of other companies' booths without prior notice during the exhibition period, including load-in/load-out work.
- (k) The chairs of the Annual Meeting and Scientific Assemblies have requested the organizer to prohibit seminars or similar events held by exhibitors during the opening hours of the exhibition and official events. In line with this request, the organizer requires exhibitors to refrain from such activities during the exhibition.

Schedule of official events other than the Scientific Conference and the exhibition

Apr.13 (Fri.)	Joint banquet for members of both societies	18:15 - 19:30 (to be booked)
Apr.15 (Sun.)	Joint closing ceremony	15:00 - 16:15 (to be booked)

- (l) Any seminars by the healthcare person in the booth are prohibited. Any presentations by the healthcare person at JIRA Strategy Corner are also prohibited. Instead, all presentations shall be made only by the exhibitor company employee or the external staff (only the narrator).
- (m) Please keep in mind the appropriate management for the exhibition held along with the Scientific Assemblies.
- (n) Decoration of booths by using the walls or ceiling of the building is prohibited. This includes actions that may result in inconvenience, such as using lighting to cast shadows on the walls or ceiling, or lighting angled in such a way that it throws light on other exhibitors' booths or passersby (spotlights, flashing lamps, laser beams, revolving lights, etc.).
- (o) In recent years, many troubles have occurred such as obstruction of passage of visitors through the booth aisle. Please consider a booth layout in order to facilitate passage of visitors.
- (p) If you violate the exhibition rules, then take a corrective action promptly. Otherwise, we may apply penal provisions later.

- (q) About installation of a door
 You cannot install the door that can be opened toward the aisle, because it hits and hurts pedestrians.

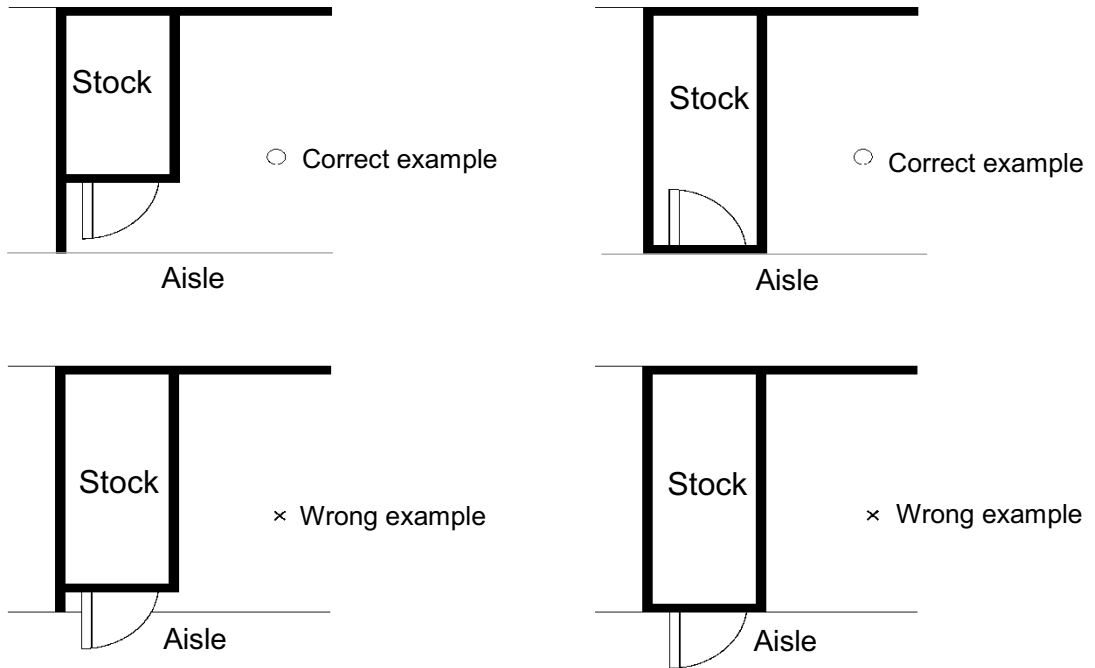

- (r) About installation of a monitor that faces the aisle
 You cannot install a monitor that protrudes towards the aisle, because it hits and hurts pedestrians.

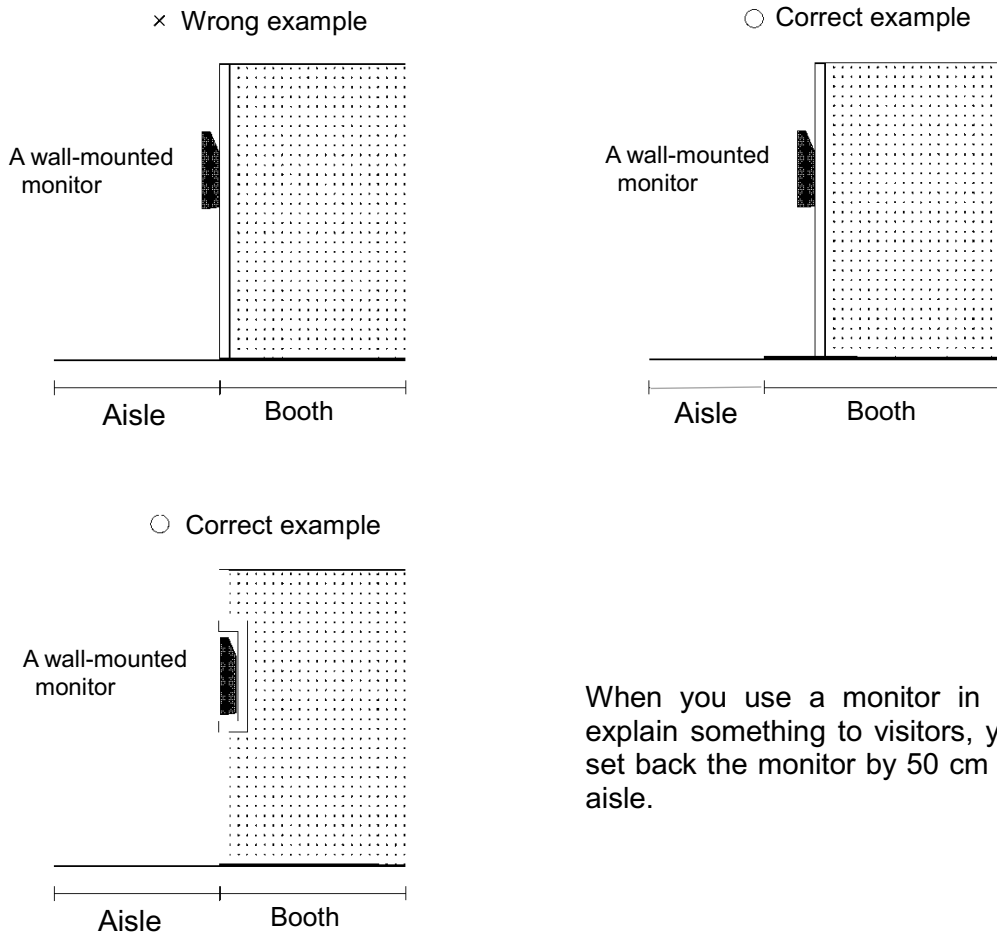

When you use a monitor in order to explain something to visitors, you must set back the monitor by 50 cm from the aisle.

10. Notes on exhibit management in space booths L and M

- (a) When you perform a demonstration in a booth, please design a booth so that it may have a large space for audience. For example, you cannot install your apparatus between a narrator's position and the aisle to perform narration toward the visitors gathering in the aisle in front of your apparatus (see pages 17 and 20).
- (b) Please refrain from the excessive loudness of your speaker, which troubles the booths of other companies.
The loudness of narration or AV equipment (multi-screen) is specified as 70 dB at the center line of aisle. Please be careful not to trouble your neighboring booths.
If the volume is too loud, then we may ask you for suspension of use.
- (c) When you use a wireless microphone in narration etc., it may interfere with the other companies. Please contact us in advance.
If interference occurs, then we may ask you to change or adjust your frequency used.
- (d) Please consult with your neighboring exhibitors in advance about the height of adjacent walls etc. Otherwise, it will cause a trouble.
- (e) Hall A accommodates the society registry office. The exhibitors in Hall A are requested to obey the loudness limitation that is severer than that of other halls (Halls B, C, and D).

11. Notes on decorations for space booths L and M

- (a) Exhibitors are permitted to use anchor bolts to install equipment on the floor and to fix decorations. However, exhibitors shall use only the anchor bolts provided by *Pacifico* Yokohama. If anchor bolts are required, please submit a **Notification of the Use of Anchor Bolts** by **Friday, Feb. 16, 2018**.

Types of anchor bolts (knock-in type) ¥1,620 per bolt

- Inner screw 10 mm, 12 mm
- Outer screw 8 mm, 10 mm, 12 mm

Anchor bolts should be removed by cutting them to floor level with a sander. If floor panels are detached owing to the use of hammers or similar to remove anchor bolts, a penalty shall be imposed on the exhibitor.

* About a violating anchor bolt

The floor slab of *Pacifico* Yokohama is thin. Therefore, please do not use your own anchor bolts. Please inform your construction contractors etc. of the cautions.

- If floor panels are detached, a penalty of ¥3,240 per bolt shall be imposed on the exhibitor.
- If carried-in bolts should be used, a penalty of ¥10,800 shall also be imposed.

*** In some areas, there are sections where the floor is weak. Please report such cases in advance to the Secretariat. If reported after anchor bolts have been affixed, please note that it will be considered as damage in all cases.**

- (b) Exhibitors are not allowed to affix decorations to walls, pillars and facilities in the site. Report any damage caused to the building or its equipment to the exhibition organizer immediately. Following discussion with the site managers and other persons concerned, the exhibitor may be requested to bear the cost of repairing such damage.
- (c) In principle, exhibitors are not allowed to add ceilings or roofs to their own booths as this may interfere with smoke detection and sprinkler function. Please note that border materials not less than 90 cm in width (including cloth), or those with an area over 9 m² in one place even when the width is less than 90 cm may be regarded as a ceiling.

However, exhibitors shall be permitted to use a ceiling or roof should light-proofing or soundproofing considerations necessitate its installation, provided that, the exhibitor apply to the local fire station in advance and ensure the safety of the facilities.

- (d) Should a ceiling or roof be required, please submit a floor plan, elevations, and working drawings (finishing materials must be shown) to the organizer by **Friday, Feb. 16, 2018**. The organizer shall submit a single application to the site covering all such requirements. When ceiling structures are used, fire extinguishers and smoke detectors must be installed in the booth. The person in charge of the site facilities shall check the booth during the ceiling/roof installation work and confirm the number of smoke detectors required before they are installed (at extra cost).

<Fire extinguishing equipment associated with the structure including roofs, etc. ¥53,460 per set>

Breakdown: Smoke detector: ¥16,200 per detector (including installation wiring works),
Test, adjustment, charge for service: ¥21,600 per company,
Burden sharing for Auxiliary fire extinguishing equipment: ¥10,800 per company,
Miscellaneous charges: ¥4,860 per company (10% of total amount of above 3 items).

For additional smoke detectors, ¥16,200 + ¥1,620 (Miscellaneous charges) per one booth shall be imposed to the exhibitors. Exhibitors will be invoiced for those charges following the end of the exhibition.

- (e) Exhibitors are not permitted to use exhibits or displays that extend outside the perimeter of the booth or exceed the height limit. Should stockroom doors form part of the booth perimeter, these may not open outward in order not to disturb passerby.
Exhibitors shall design the height and form of floors to avoid visitors stumbling on them. If visitors suffer from the accident such as injuries etc., then the company in the corresponding booth shall be liable for indemnification for such damages (see page 11).
- (f) Exhibitors are required to take away all their own packaging, display, and waste materials. If any garbage is left after dismantling, the organizer shall dispose of this and the exhibitors shall be invoiced for the cost of disposal.
- (g) During load-in/load-out work, please do not leave display materials etc. unattended in the aisle.
- (h) About the open field of a booth of 100 m² or more (see page 22, figure 8.)
You can close a field except the field facing a main aisle (see pages 24 and 25, figure 10). However, when you close a field, please prepare an emergency evacuation passage of 2 m or more within the closed field. If a 2-m emergency passage at the edge of a closed field is not regarded as an emergency passage. The booth smaller than 100 m² does not need an emergency passage. Your plan will be accepted after we check the submitted drawing in respect to the hall fire-fighting equipment.
- (i) The height of booth spaces L and M is as follows:
- For booth spaces adjacent to the wall with the back to the corner, the height limit is 6.0 m for both L and M and 4.5 m for 1/4 on the aisle side.
 - For booth space L in a central location not adjacent to a corner, the height limit is 4.5 m, and no restrictions will be set for 1/4 on the aisle side.
 - For booth space M in a central location not adjacent to a corner, the height limit is 4.5 m and 3.6 m for 1/4 on the aisle side.
- (See page 17, figures 1-1-1 and 1-2-1, and page 18, figure 1-3-1)
- (j) Please consult with the exhibitors of your adjacent booths about the color etc. of adjacent wall, if the height of the adjacent wall is different each other. The exhibitor of higher wall shall be responsible for a finish work (see page 23, figure 9).

- (k) A boundary within 1 m of a neighboring booth is regarded as a wall, and the display of company names and logos in the direction of (facing) another company is prohibited.
- (l) When preparing the stage for narration, you need a setback from a booth boundary line in order to secure space for audience. A setback should be either "a stage height x 2", or "a booth length at the side of the boundary line for the stage x 1/4", whichever longer. We will check the submitted drawing and may ask you for correction. In that case, please accept our request (see page 17, figures 1-1-2 , 1-2-2 and page 18, figure 1-3-2).
- (m) When narrators use a microphone to perform a demonstration, if they speak toward the booth center, they may stand anywhere they want. If they speak toward an aisle, they need a setback that is 1/4 of the length of booth facing the aisle. The standing position of narrator and the direction of narration should be indicated in red on the plan view to be submitted (see page 17, figures 1-1-2 , 1-2-2 and page 18, figure 1-3-2).
- (n) We do not see the elevated booth floor as a stage. Please take the safety measures to prevent danger (a slope, an attention-getting billboard etc.) so that visitors may not stumble.
- (o) When your display has a driven part, please design your layout in order to prevent visitors from entering the operation area of the driven part. In this case, a narrator should stand as shown in figures 1-2 and 2-2. You cannot install your display between a narrator's position (including the operation area) and the aisle to perform narration toward the visitors gathering in the aisle in front of your display. Please secure a sufficient space (see page 20, figures 4-2 and 5-2).
- (p) You cannot use an advertising balloon (helium gas) for decoration.
- (q) Height restrictions on lighting equipment, speakers, etc.

As shown in the figure below, speakers and lighting equipment, etc. cannot be installed above the height restrictions for the space booths (L and M). However, if lighting the company name, etc. using lighting equipment such as a mini spot light or arm spot light, it may protrude up to 30 cm into the aisle. The protrusion of large-sized lighting equipment (mercury lamps and other bright, glaring lights) is prohibited. Please note that if there are issues with the brightness and direction of the lighting at the venue, we may ask that these issues be addressed.

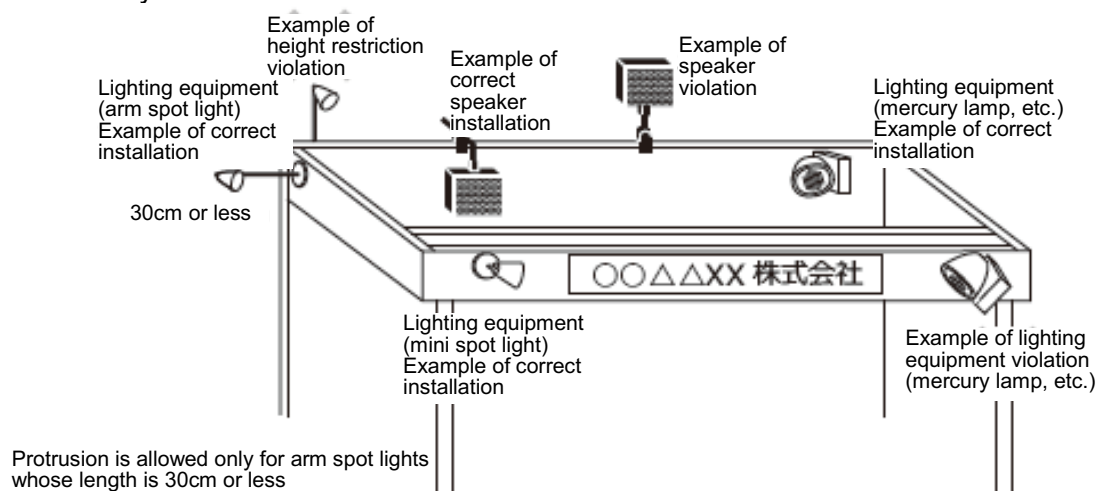

- (r) We must submit all the drawings of the space booths L and M to *Pacifico* Yokohama (disaster- prevention department).
Please submit the following drawings to us by **Fri., February 16, 2018.**
(1) Booth plan view, Two copies

- Please specify adjoining booths.
 - When there is a ceiling structure, please specify it in a plan view with a red slash.
- (2) Elevational view, Two copies
- When there is ceiling structure, please specify it in a plan view with a red slash.
 - Please specify materials (cloth, wood, sheet, etc.) for a ceiling.
- (3) Plan illustrating the structure with a bird's-eye view / perspective, Two copies.

12. About Two-Story structure in space booths L and M

- (a) You cannot construct a Two-Story structure in a booth, because it disturbs the functions of a fire alarm and a sprinkler.

However, you can construct it if the fire department has approved your prior application in terms of disaster prevention equipment and safety.

- (b) When you construct a stage or elevate a floor, if its height is 2 m or more, then it shall be regarded as a Two-Story structure. In addition, even when its height is less than 2 m, if the space under a stage or an elevated floor is used for a repository, then it shall be regarded as a Two-Story structure (see page 25, figure 11).

- (c) If you construct a Two-Story structure, please submit the following drawings and documents by the deadline.

Submission deadline: **Fri., February 16, 2018**

Documents to be submitted	Number of copies	Remarks
Application for Two-Story and ceiling structure	1	Form 8
Structural calculation sheet	2	It must be drafted by a first-class registered architect according to the booth drawing. It must be signed and sealed by the said architect to guarantee safety.
Two-Story structure catalog	2	When a structure is a ready-made article, the maker' catalog must guarantee the strength of structure.
Plan illustrating the structure with a bird's-eye view / perspective	2	The data for explanation to the fire department and the site disaster-prevention staff
Plan view	2	Please specify adjoining booths. When there is a ceiling structure, please specify it in a plan view with a red slash. Please specify materials (cloth, wood, sheet, etc.) for a ceiling.
Elevational view	2	
Manufacture working drawing	2	The drawing that specifies the booth materials, especially the materials for foundation and finish of a Two-Story structure

- (d) Notes on a design of Two-Story structure, construction, and management, etc.
- (1) The Fire Service Law mandates the two-way escape routes. Please be sure to construct two stairs (for different fields).
 - (2) Size of each step of stairs
 - 90 cm or more in width
 - 22 cm or less in height
 - 21 cm or more in depth
 - (3) Please construct a handrail of 1.2 m or more in height to prevent a fall from stairs.
 - (4) You cannot construct a ceiling (including cloth) over the upper part of a Two-Story structure.
 - (5) You cannot use fire (open flame) in the hall (booth).
 - (6) You cannot do a welding work (electricity, gas, etc.) for construction and disassembly.
 - (7) Please deploy staff members who control the number of visitors entering a Two-Story structure so that it may not exceed the limit specified by the structural calculation sheet.
 - (8) In the case of an emergency, please deploy staff members who guide visitors in a booth.
 - (9) Please install one set of fire extinguisher per 50 m².
 - (10) Please install an automatic fire alarm.
The spot will be checked by *Pacifico* Yokohama exhibit hall operation group, and the required number of alarms will be installed.
The expenses etc. are the same as a smoke detector mentioned on page 13, item (d).
 - (11) In the case of Two-Story structure, emergency exit sign lighting must be installed according to a layout. In this case, please install the lighting at the place as instructed.

13. Figures for space booths L and M showing cautions

Space booth (when three sides face the aisle and one side faces the corner or other companies)

Figure 1-1-1 Height limitation

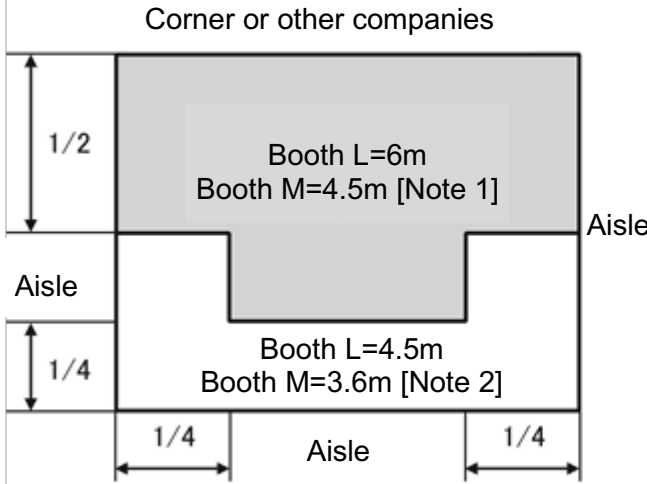

Note 1: The limit is 6 m if one side faces the corner.
 Note 2: The limit is 4.5 m if one side faces the corner.

Figure 1-1-2 Narrator's position

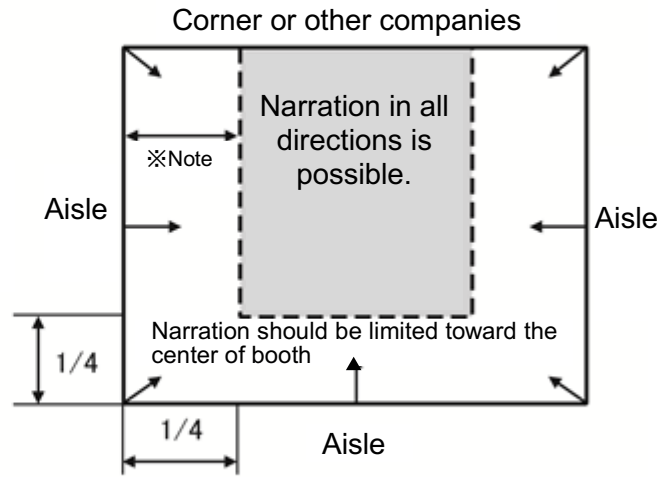

※Note
 The setback must be (the stage height) x 2.
 The setback must be at least 1/4 or more.

Space booth (when two sides face the aisle and two sides face the corner or other companies)

Figure 1-2-1 Height limitation

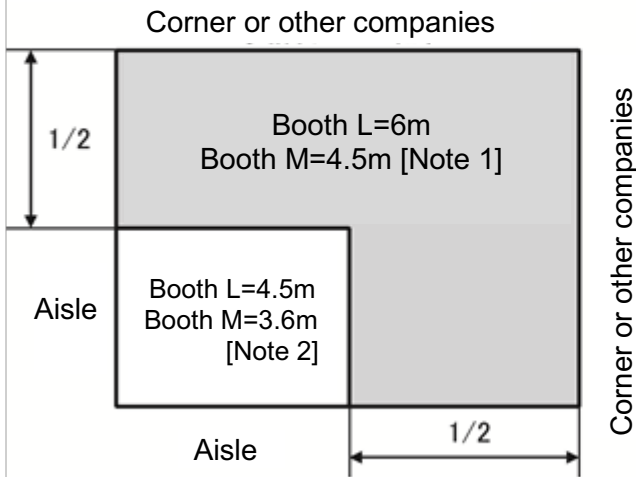

Note 1: The limit is 6 m if any side faces the corner.
 Note 2: The limit is 4.5 m if any side faces the corner.

Figure 1-2-2 Narrator's position

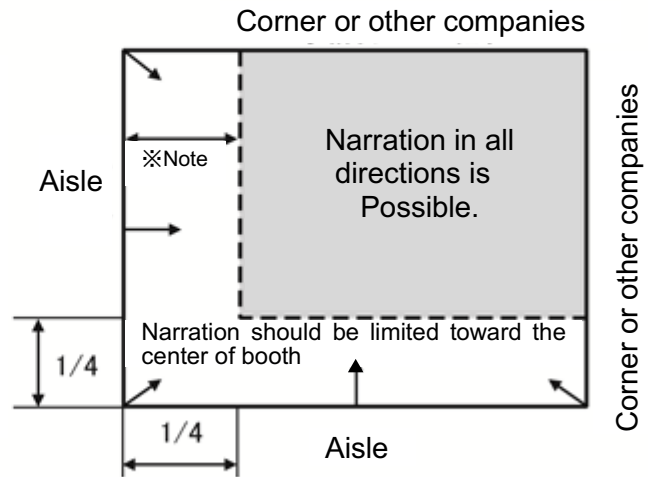

※Note
 The setback must be (the stage height) x 2.
 The setback must be at least 1/4 or more.

Space booth (when four sides face the aisle)

Figure 1-3-1 Height limitation

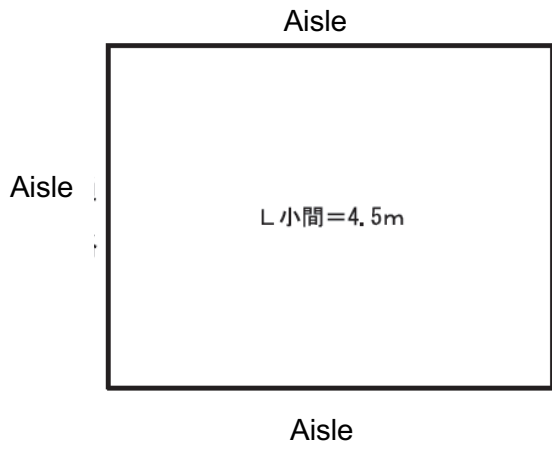
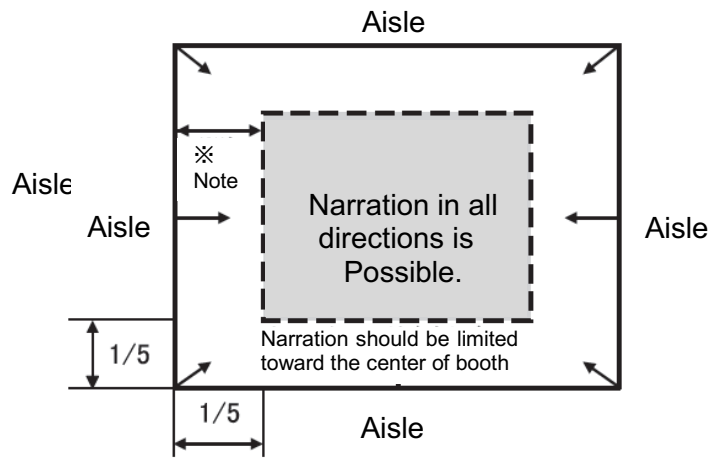

Figure 1-3-2 Narrator's position



※Note
The setback must be (the stage height) x2.
The setback must be at least 1/5 or more.

The audience space at the time of narration

Figure 3-1

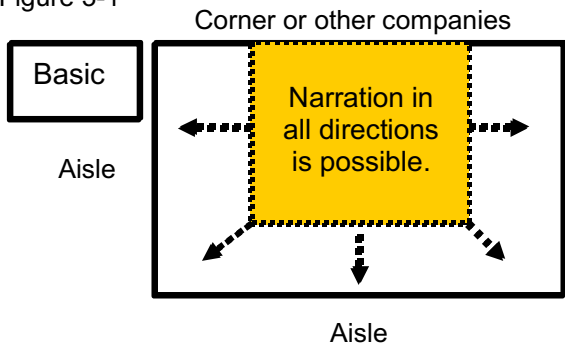

Figure 3-2

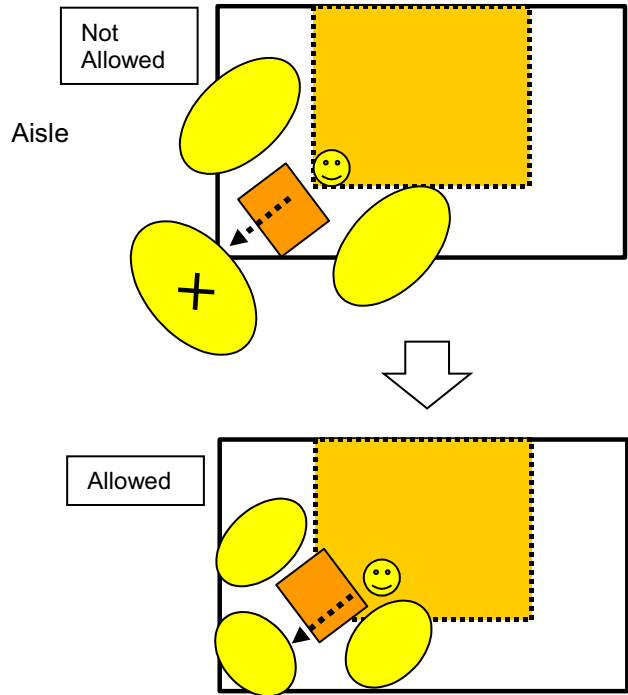
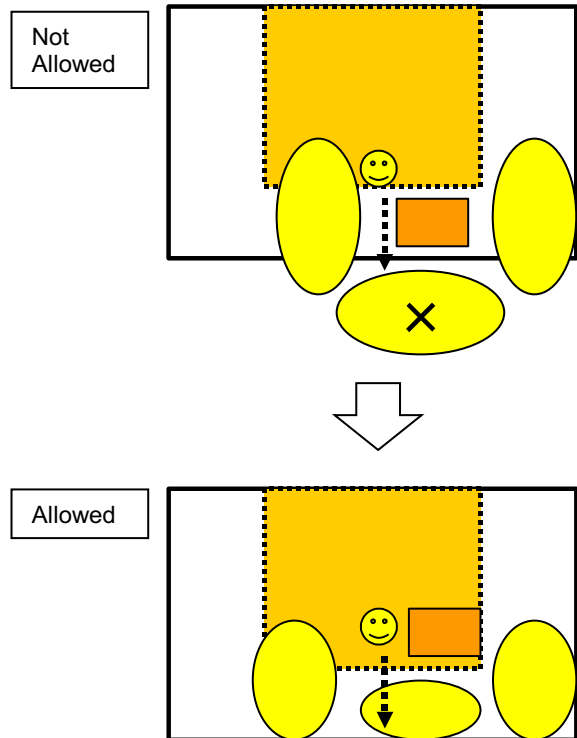

Figure 3-3



Display and narration of product having the driven parts

Figure 4-1 Without a narrator

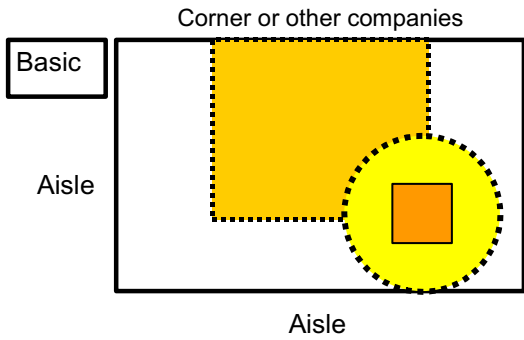
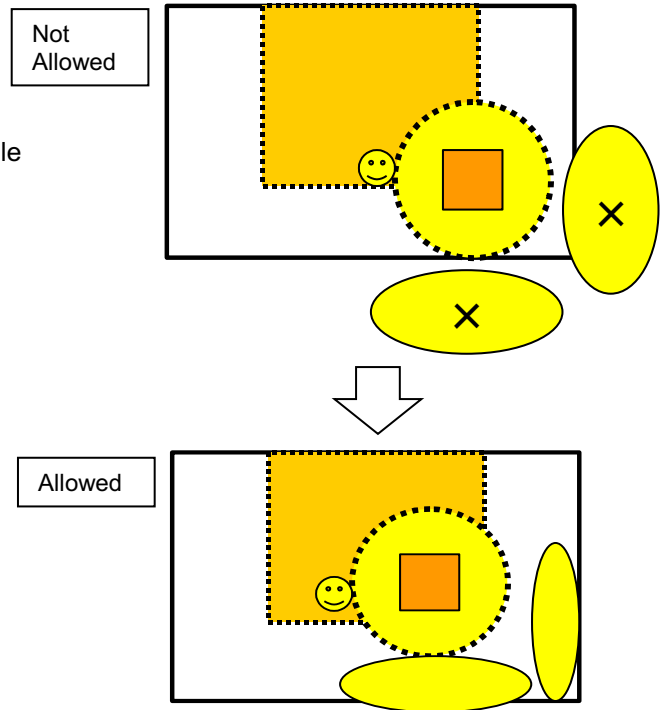

Figure 4-2 With a narrator



Display and narration of product having the moving parts

Figure 5-1 Without a narrator

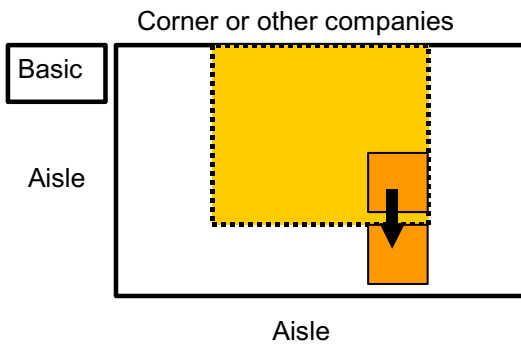
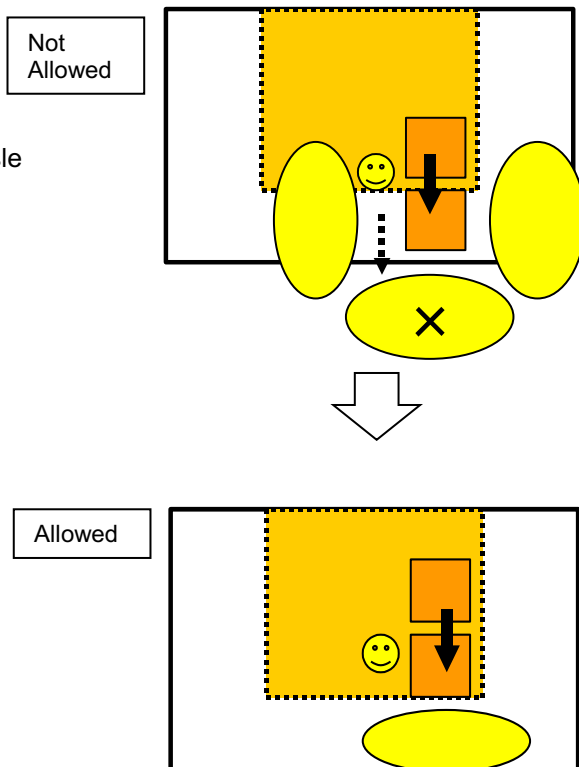

Figure 5-2 With a narrator



What is a corner?

Figure 6-1

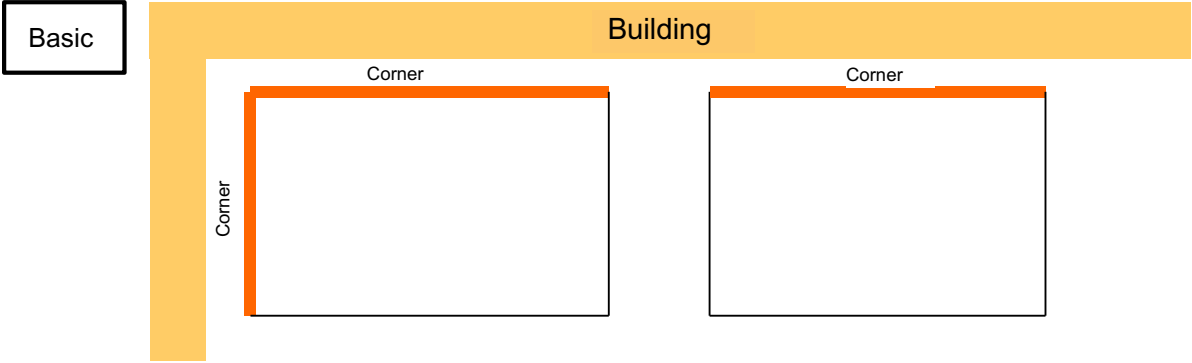

Figure 6-2

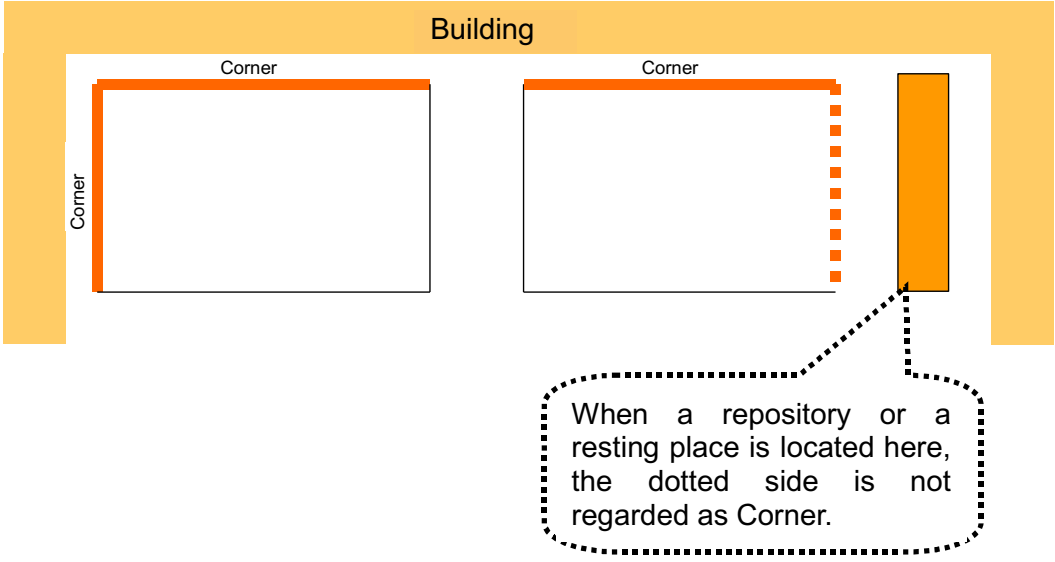
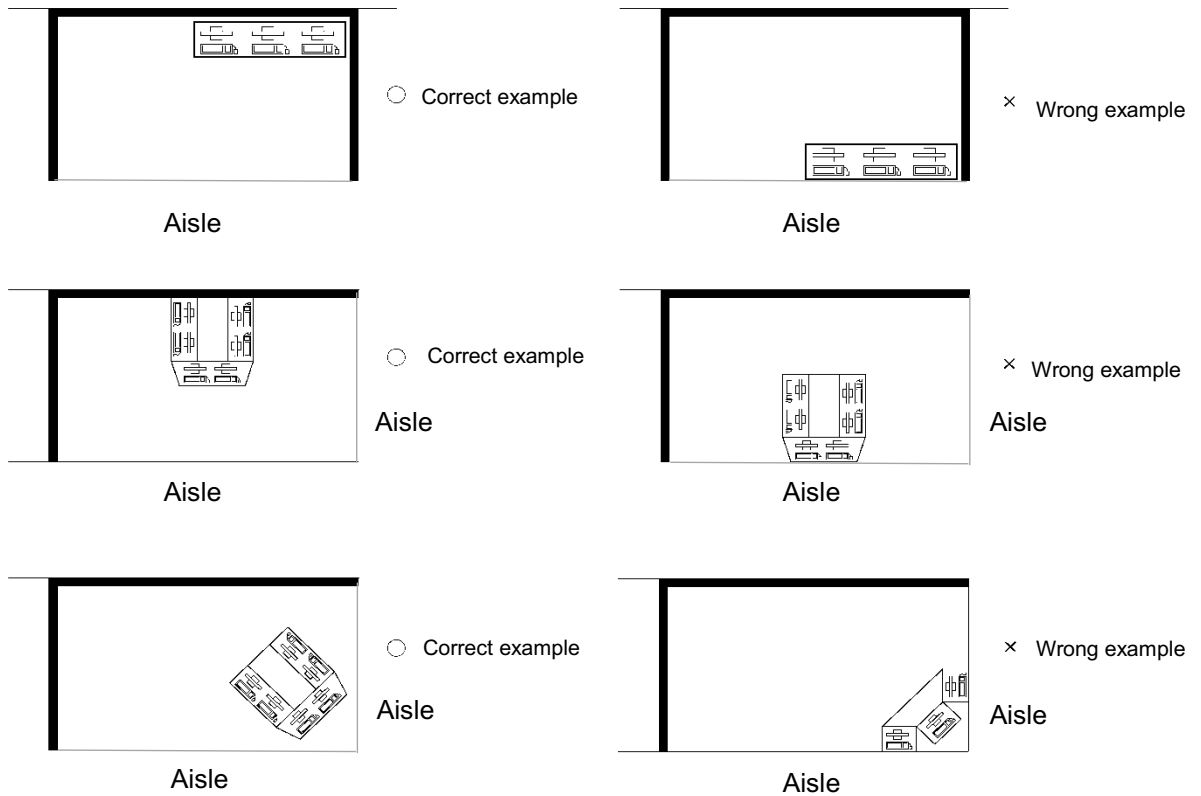

Figure 7 About installation of the exhibition stand at the aisle side of a space booth. Visitors should be gathered not in an aisle but in a booth.



The exhibit stand (excluding a reception desk and decorations) should be set back by 50 cm inward from the aisle.

Figure 8 About open field of booth more than 100 m²

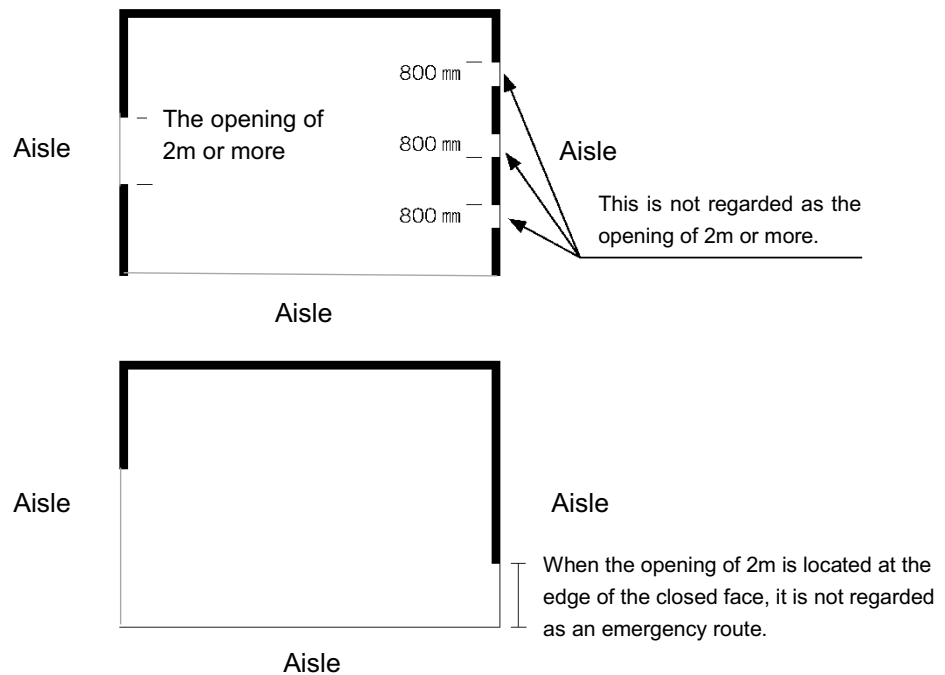
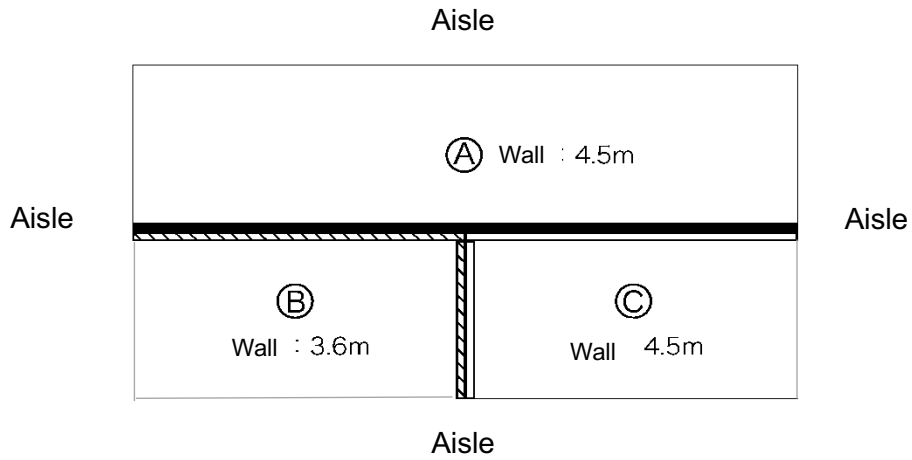
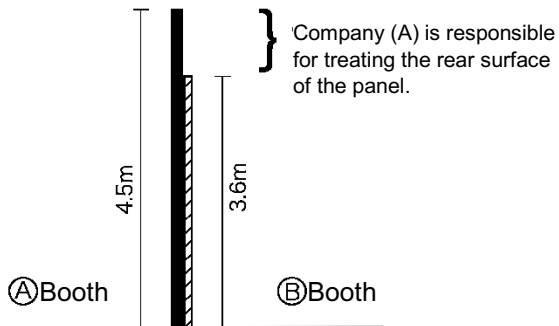

Figure 9 About boundary wall of adjoining booth

It should be negotiated among the companies concerned.



Wall of between booth (A) and booth (B)



Wall of between booth (B) and booth (C)

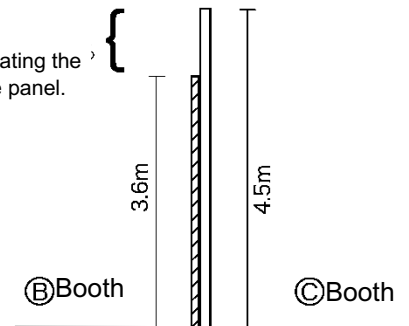

Wall of between booth (A) and booth (C)

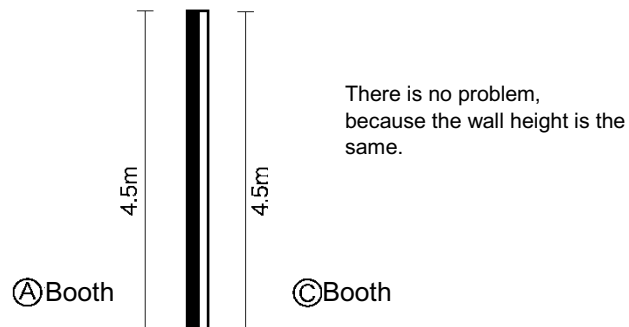
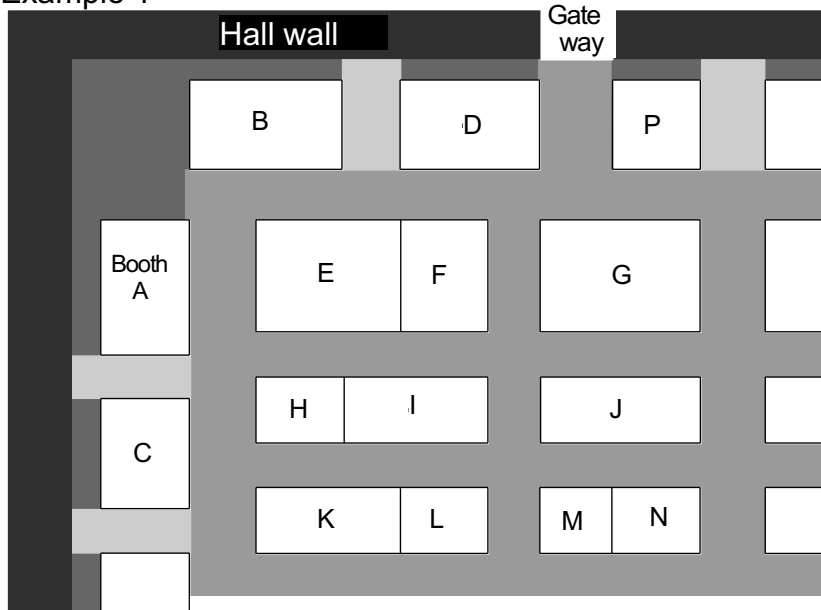

Figure 10 What is a main aisle?

Example 1



- not a main aisle
- a main aisle
- a corner

Example 2

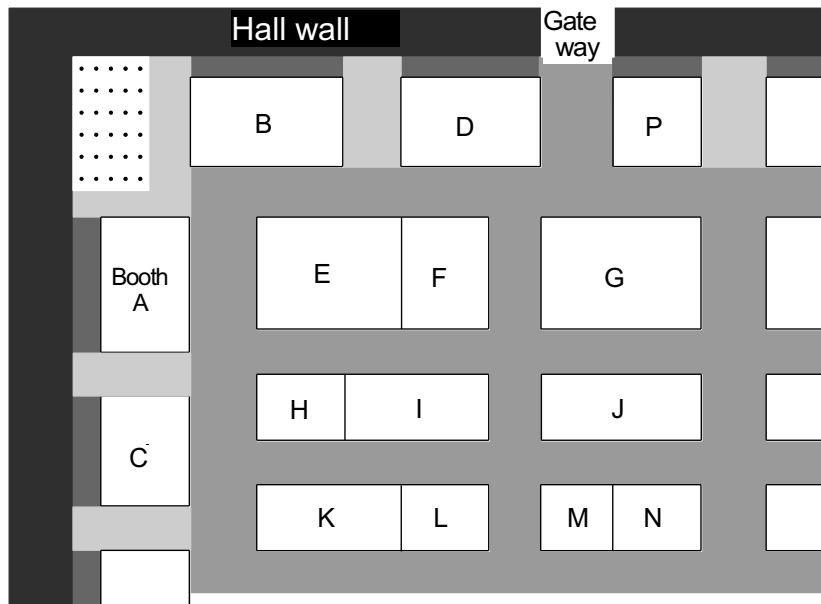

- not a main aisle
- a main aisle
- a corner
- a resting placer

Example 3

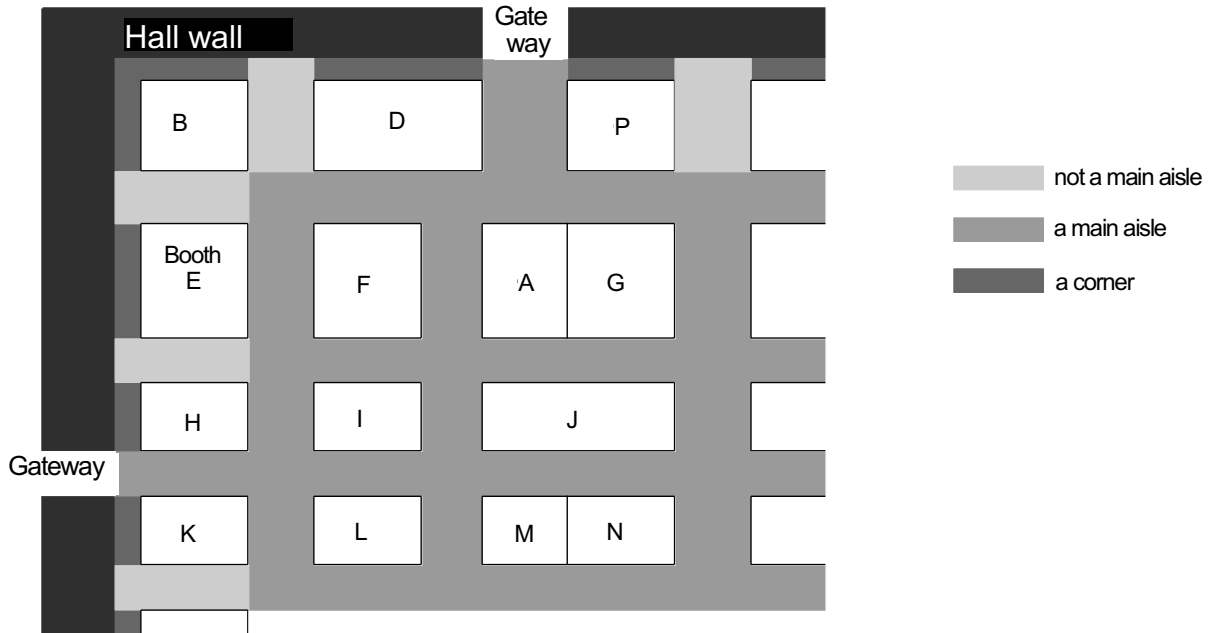
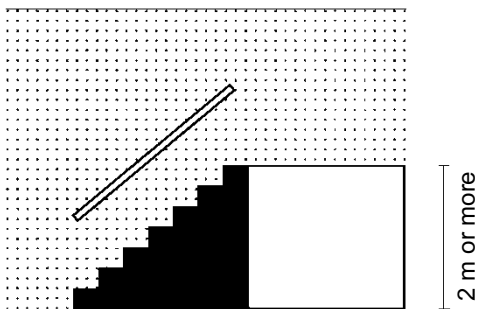
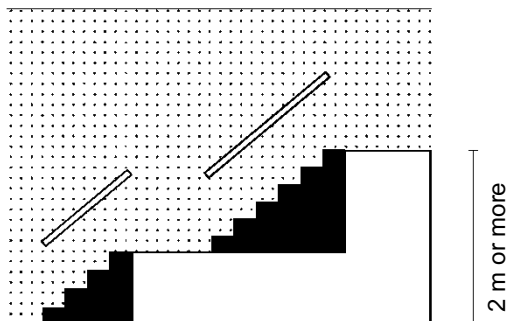

Figure 11 About handrail of stairs



When you construct a stage or elevate a floor, if its height is 2 m or more, then it shall be regarded as a 2-story structure and the handrail must be installed. In addition, even when its height is less than 2 m, if the space under a stage or an elevated floor is used for a repository, then it shall be regarded as a 2-story structure.



In the case stairs, if the height of top floor is 2 m or more, then a handrail must be installed.

14. Notes on decorating work in booths with basic fittings

- (a) Exhibitors in booths with basic fittings are not permitted to narrate by using microphone.
- (b) In the case of booths with basic fittings, when a screen is installed on the wall facing the aisle and animation etc. is broadcast toward the aisle, only one set of 42 or less inch size is allowed. Please be careful not to trouble to the surrounding booths (for example high-intensity images, images of fluctuating brightness, etc.)
- (c) When the wall facing the aisle is used and animation etc. is broadcast toward the aisle, only an edited footage is allowed. In this case when a narrator speaks, the setback of 50 cm or more is needed.
- (d) Exhibitors are permitted to use anchor bolts to install equipment on the floor and to fix decorations. However, exhibitors shall use only the anchor bolts provided by *Pacifico Yokohama*. If anchor bolts are required, please submit a **Notification of the Use of Anchor Bolts by Friday, Feb. 16, 2018.**

Types of anchor bolts (knock-in type) ¥1,620 per bolt (including consumption tax)

- Inner screw 10 mm, 12 mm
- Outer screw 8 mm, 10 mm, 12 mm

Anchor bolts should be removed by cutting them to floor level with a sander. If floor panels are detached owing to the use of hammers or similar to remove anchor bolts, a penalty shall be imposed on the exhibitor.

* About a violating anchor bolt

The floor slab of *Pacifico Yokohama* is thin. Therefore, please do not use your own anchor bolts. Please inform your construction contractors etc. of the cautions.

- If floor panels are detached, a penalty of ¥3,240 (including consumption tax) per bolt shall be imposed on the exhibitor.
- if carried-in bolts should be used, a penalty of ¥10,800 (including consumption tax) shall also be imposed.

***In some areas, there are sections where the floor is weak. Please report such cases in advance to the Secretariat. If reported after anchor bolts have been affixed, please note that it will be considered as damage in all cases.**

- (e) Exhibitors are not allowed to affix decorations to walls, pillars and facilities in the site. Report any damage caused to the building or its equipment to the exhibition organizer immediately. Following discussion with the site managers and other persons concerned, the exhibitor may be requested to bear the cost of repairing such damage.
- (f) In principle, exhibitors are not allowed to add ceilings or roofs to their own booths as this may interfere with smoke detection and sprinkler function. Please note that border materials not less than 90 cm in width (including cloth), or those with an area over 9 m² in one place even when the width is less than 90 cm may be regarded as a ceiling.
However, exhibitors shall be permitted to use a ceiling or roof should light-proofing or soundproofing considerations necessitate its installation, provided that, the exhibitor apply to the local fire station in advance and ensure the safety of the facilities.
- (g) Should a ceiling or roof be required, please submit a floor plan, elevations, and working drawings (finishing materials must be shown) to the organizer by **Friday, Feb. 16, 2018**. The organizer shall submit a single application to the site covering all such requirements. When ceiling structures are used, fire extinguishers and smoke detectors must be installed in the booth. The person in charge of the site facilities shall check the booth during the ceiling/roof installation work and confirm the number of smoke detectors required before they are installed (at extra cost).

<Fire extinguishing equipment associated with the structure including roofs, etc. ¥53,460 (including consumption tax) per set>

Breakdown: Smoke detector ¥16,200 (including consumption tax) per detector (including installation wiring works),
Test, adjustment, charge for service ¥21,600 (including consumption tax) per company,
Burden sharing for Auxiliary fire extinguishing equipment ¥10,800 (including consumption tax) per company,
Miscellaneous charges ¥4,860 (including consumption tax) per company (10% of total amount of above 3 items).

For additional smoke detectors, ¥16,200 + ¥1,620 (Miscellaneous charges) per one booth shall be imposed to the exhibitors. Exhibitors will be invoiced for those charges following the end of the exhibition.

- (h) Exhibitors are not permitted to use displays that extend outside the perimeter of the booth. Should stockroom doors form part of the aisle side, these may not open outward in order not to disturb passerby. Exhibitors shall design the height and form of floors to avoid visitors stumbling on them. Should visitors suffer from the accident such as injuries etc., the company in the corresponding booth shall be liable for indemnification for such damages (see pages 11).
- (i) **The maximum height for decorations is 2.7m. Height and protrusion into the aisle of mini spot lights and arm spot lights is allowed up to 30cm. However, the protrusion of large-sized lighting equipment (bright, glaring lighting such as mercury lamps) is prohibited. Speakers, etc. must be installed within the booth. Please note that if there are issues with the brightness and direction of the lighting at the venue, we may ask that these issues be addressed (see figure below).**

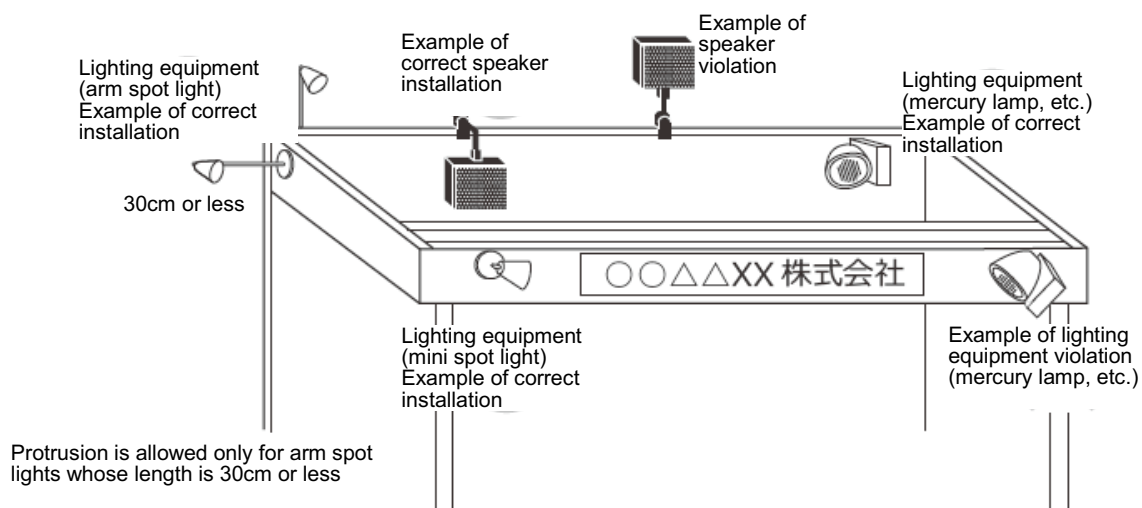

- (j) **Company name plates that protrude are prohibited. Nothing other than the company name may be displayed on the parapet or at this location.**
- (k) Exhibitors are required to take away all their own packaging, display, and waste materials. Should any garbage be left after dismantling, the organizer shall dispose of this and the exhibitors shall be invoiced for the cost of disposal.
- (l) During load-in/load-out work, please do not leave display materials etc. unattended in the aisle.
- (m) The aisle side of each booth shall be open. For corner booths, two sides shall be open.
- (n) System panels, side walls, floor carpets, parapets with company names backlit with

fluorescent lighting will be provided to exhibitors.

- (o) Exhibitors are not permitted to use rivets or nails on panels.
- (p) Use clip-type clamps to fix spotlights etc. on panel walls and poles. Nails or clamps may not be used.
- (q) Posters, lightweight photo panels no larger than A1 size (such as dry mounting) or cut sheets can be posted on panel walls and poles with double-sided tape. Exhibitors shall return the walls and poles to their original states when exhibits are removed.
- (r) Exhibitors are not allowed to cut or process the panel walls and poles.
- (s) Exhibitors are not permitted to put exhibits or decorations directly on panel walls and poles, or to remove supports such as pillars.
- (t) **In principle, a side wall with a length of 1980 mm for booth A (booth depth: 2970 mm) and 990 mm for booth B (booth depth: 1980 mm) shall be installed (see the figures at next pages). However, under exceptional circumstances, additional side walls can be installed to close the booth if approval can be obtained after discussions with the neighboring booth. A fee will be charged: To be paid by the client/requestor, and an invoice will be sent by the construction company (see page 33, item 22.(a)). In case a notification of closure is received with a "Notification of Decoration Work", the Exhibition Secretariat will notify the phone number and email address of the person(s) in charge of the adjoining booth. Please approve of the disclosure. Additional side walls shall not be installed if an agreement cannot be reached with the neighboring booth. Also, even if a side wall is installed according to the standard specifications, be sure to consult the person responsible for the neighboring booth and obtain approval if the exhibit items or reception areas are located in any areas without side walls.**
- (u) When using more than two units, in addition to the pillars at both sides in front of the units, additional pillars shall be set up to reinforce the parapets. (If two units are used, one additional pillar shall be set up at the center of the front side. If three units are used, two additional pillars shall be set up. If four units are used, three additional pillars shall be set up. The numbers of additional pillars shall be increased in line with the number of booths.) Should such additional pillars obstruct exhibitions, exhibitors are permitted to detach parapets and add display materials. Please apply by submitting a **Notification of Decoration Work**. In this case, parapets shall not be attached together with company name plates. Direct applications on site may not be accepted since workmen may not always be available. After parapets have been detached, the exhibitor shall carry out installation of display materials.
- (v) If you are not sure whether your lighting equipment and decorations meet the rule, then please contact us in advance.
- (w) If you need any fixtures and exhibition stands for booths with basic fittings, then please contact decorating company for basic fittings (see page 33, item 22.(a)).

15. Drawing of booth with Basic fittings

Booth A with Basic fittings

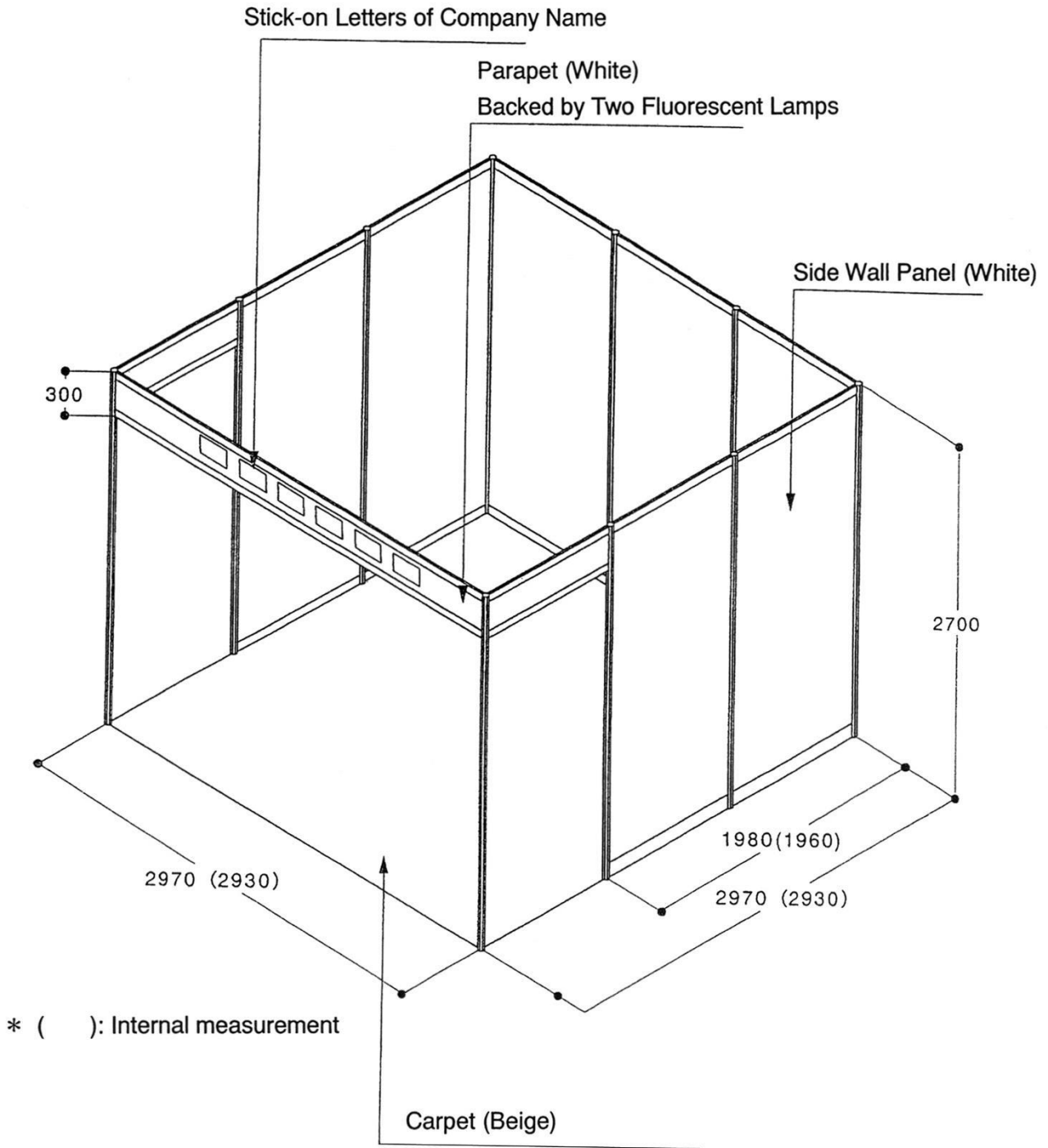

Booth B with Basic fittings

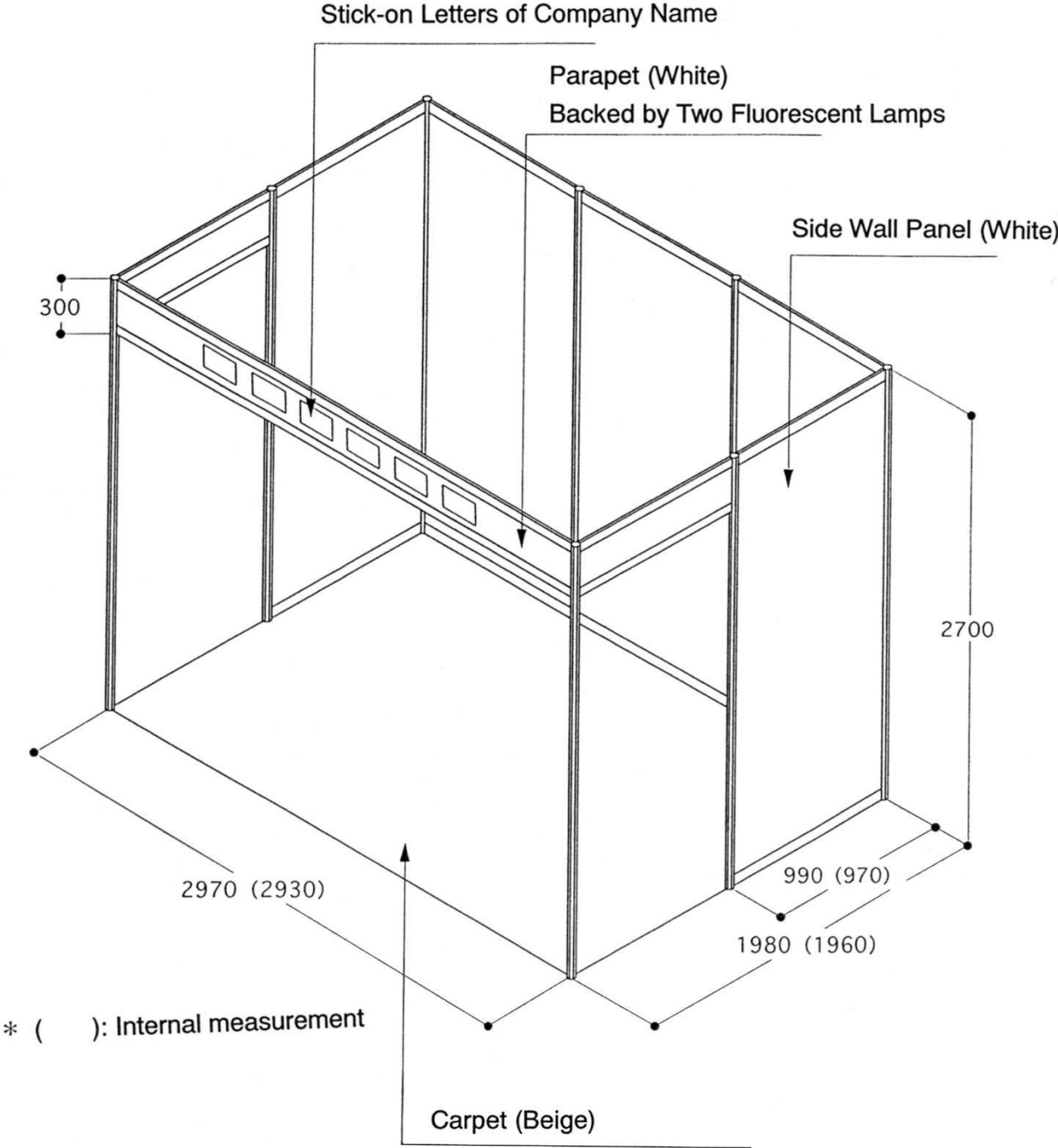

16. Electricity

- (a) The existing ceiling lights are used for general lighting.
- (b) In principle, you are not prohibited to use the electric wiring pit in your booth and to install your own wiring. The pit belongs to the exhibition site and the pit-related installation is allowed only to the appointed contractors. In order to ensure safety and to prevent the possible power supply accidents, please do not install you own wiring beyond the service entrance switches in the pit.
- (c) To request electric power supply for displays, demonstrations, and lighting, submit the **Power Supply Application Form** by **Friday, Feb. 16, 2018**.
- (d) Electric cabling will be installed in each booth. Exhibitors are responsible for the cost of installing electric cabling (connected to a service entrance switch in each booth) and electricity charges (for their own load-in/load out work and exhibitions).

Exhibitors shall be charged for the amount of electricity consumed after the exhibition closes.

- (e) One wall socket with two outlets is installed for electric power (100 V, 500 W) for booths with basic fittings. Please inform the organizer of any modification including no installation required, larger capacity, additional outlets, or use of 200 V by submitting the Power Supply Application Form.
- (f) Exhibitors shall carry out electrical work within their own booths, such as wiring from the lead-in switch. Should no workmen be available, exhibitors are permitted to request the electrical contractors listed on page behind to perform such work (cost to be borne by the exhibitor).
- (g) Three types of electricity supply are available: 50 Hz, 1φ-100 V, 1φ-200 V, and 3φ-200 V
- (h) Installation of earths (interpretation of Technical Standards for Electrical Facilities: Clauses 10, 11, 20, and 29)
 Steel tables and outer cases of machinery and appliances must be earthed, unless machinery and appliances with voltage to ground not exceeding 150 V are placed in a dry location.
 Low voltage not exceeding 300V D-type earthing: Not exceeding 100 Ω
 Low voltage over 300V C-type earthing: Not greater than 10 Ω
 Use soft copper wires 1.6 mm in diameter or equivalent that are corrosion-resistant and conduct fault current safely.
- (i) Start and cutoff dates for power

Start date	April 10 (Tue.)	Approx. 14:00
During exhibition	April 13 (Fri.)	8:00 – 18:00
	April 14 (Sat.)	9:00 – 18:00
	April 15 (Sun.)	9:00 – 16:00

If a temporary power supply is needed before the dates power supply is started or cut off, fill in the dates, times, and power consumption required on the Power Supply Application Form and submit it by **Friday, Feb. 16, 2018**.

- (j) During the exhibition, maintenance electricians will be available on-site to carry out maintenance work. However the organizer shall not compensate for damage to exhibits caused by power failure for reasons such as power supply interruption, power cuts, and voltage drops. Please implement protective measures for exhibit demonstrations accordingly.

17. Telephones and communication lines

- (a) Exhibitors who wish to install telephones (analog only) in their respective booths may apply directly to Pacifico Yokohama with the Temporary Telephone Line Application Form (Form 9-1) by **Friday, March 9, 2018**. Please indicate **the number of telephones required and where they are to be installed in red** on the application form.

Note: If the location of the telephones has not been determined, submit this information at a later date.

- Please note that we may be unable to grant requests for last minute cancellations immediately prior to the start date. In such cases, you may be invoiced for the installation fee.
- Separate international call fees apply for international calls.
*Please note that ADSL lines cannot be used.

About fees: Installation fees and telephone charges

8,640 yen (tax inclusive) (includes one telephone). Telephone charges will be assessed separately and are the responsibility of the exhibitor.

For details, please contact Pacifico Yokohama.

The amount will be invoiced directly from Pacifico Yokohama.

- (b) Exhibitors who wish to install optic line (B Flets) and Wifi in their respective booths may apply directly to Pacifico Yokohama with the Application Form (Form 9-2) by **Friday, March 9, 2018**.

18. Handling of communication devices (excluding wireless LAN devices [Wi-Fi, Bluetooth])

- (a) It is required to submit a prior application to the administrative office for the transmission of signals within the company booth, between other company booths within the venue, or to devices outside the venue (except for wireless LAN devices [Wi-Fi]). (No specified forms are available.)
Permission will be granted if this is determined not to have any effect on other exhibitors.
- (b) Use only wireless equipment that is legally authorized (under the Radio Law and other legislation).
- (c) Use mobile phones, transceivers, and other devices in such a way that they do not inconvenience other exhibitors or persons nearby.

19. Consumption of Food and Drink

- (a) Because of the regulations of the Japan Fair Trade Council of the Medical Devices Industry, food (including drinks and confectioneries) is not allowed in the booth in principle. However, as an exception, tea and snacks may be provided during meetings with medical professionals held in an independently established negotiation corner within the company booth.
- (b) Please be aware that in certain circumstances the local Health Center may issue instructions to suspend or terminate the consumption of food and drink during the exhibition.

20. Cleaning

- (a) Each exhibitor is responsible for taking away trash (decoration/packing materials) incurred in installation and load-in/out.

- (b) The small amount of trash made during the exhibition period shall be put away in the designated trash location in the hall.
- (c) The exhibitor is responsible for cleaning within the booth.
- (d) The interior of the site will be cleaned from 17:00 on Thursday, Apr. 12. Exhibitors' cooperation is requested.
- (e) After dismantling, exhibitors are requested to make a final check that there are no marks, remaining materials, double-sided tape, remains of glue, or other such problems on the site of their booth.

21. Fire and Disaster Prevention

- (a) The introduction and exhibition of hazardous substances (oils, explosives, poisons), naked flames (including propane gas, heaters, etc.), and high-pressure gas are prohibited. (Also listed under Prohibitions.)
- (b) Display materials such as veneer sheets, carpets, and fabric such as curtains may not be used unless they display a "Fireproofed" mark.
- (c) Smoking is prohibited inside the site during load-in/load-out, display, fixing, and the duration of the exhibition.

Exhibitors are particularly requested **to ensure that their contractors observe this strictly**. Smoking should only take place in the prescribed smoking areas. Smoking areas may not be set up within booths.

- (d) Regardless of the floor area of booths, fire extinguishers must be placed throughout the site in accordance with instructions by the fire department. The organizer will place fire extinguishers in appropriate locations. Exhibitors' cooperation is appreciated.

In two-story booths, a fire extinguisher should be placed on the second floor. (The cost is to be borne by the exhibitor.)

22. Recommended contract companies

The secretariat introduces the following companies. Please contact directly as required.

- (a) Decorating company for basic fittings, system panel options, accessory rental, etc.
Three-B, Inc.
Erde Hongo-kan Bldg, 5F 3-6-9 Hongo, Bunkyo-ku, Tokyo 113-0033 Japan
Phone: 81-3-5805-1055 Facsimile: 81-3-5805-1058
Persons in charge: Ryosuke Iida <mailto:iida@threeb.co.jp>
- (b) Electric installation for additional cabling and sockets, spotlights, etc.
Event Business Division of IIDA Electrical Works Co., Ltd.
1-8-21, Shinkiba, Koto-ku, Tokyo 136-0082 Japan
Phone: 81-3-3521-3522 Facsimile: 81-3-3521-3524
Persons in charge: Ikunosuke Nakamura
- (c) Temporary personnel dispatch for hostesses, narrators, etc.
YUUSEI LTD.
RoseBay Shintomityo Bldg. 3F 2-3-16, Shintomi, Chuoh-ku, Tokyo 104-0041, Japan
Phone: 81-3-3523-0612 Facsimile: 81-3-3523-0614
Person in charge: Kazuhiro Wakui and Hideomi Sekiguchi

- (d) Carrier: Tokyo Buturyuu Co., Ltd.
3-14-8 Tatumi Koutou-ku, Tokyo 135-0053, Japan
Phone: 81-3-5569-2281 Facsimile: 81-3-5569-2280
Person in charge: Masaru Arai and Masateru Higuchi
- (e) Venue: *Pacifico* Yokohama
1-1-1 Minato Mirai, Nishi-ku, Yokohama, 220-0012, Japan
Phone: 81-45-221-2160 & 2121 Facsimile: 81-45-221-2136
Persons in charge: Takaya, Akai
- (f) **Parcel Delivery: Pacifico Logistics Center (Yamato Transport Co., Ltd.)**
Tel 080-6699-3349
Persons in charge: Mitsuru Satoh
http://www.pacifico.co.jp/visitor/shops/shops_logicenter.html

23. About our responsibility and your expenses

- (a) The sponsor and the operator of the exhibition will pay attention to the exhibition as a good manager and take general control of the exhibition hall. However, we assume no responsibility for any accidents caused by force majeure, including a natural disaster. In such a case, the exhibitors shall protect your own exhibits.
- (b) In setting up, during exhibition period and in carrying out, the exhibitors shall secure a reliable management of your own exhibits and decorative structures and pay much attention to prevention of accidents. The exhibitors shall also take appropriate measures, such as buying an insurance, to prepare for theft, loss or any other accidents of your own exhibits.
- (c) The exhibitors shall bear all expenses relating to your own exhibition including cost for transporting, carrying in, exhibiting and carrying out your exhibits and insurance fee.
- (d) The costs of any work involving the use of electrical main lines; costs for violations of the use of anchor bolts and subsequent repairs; costs associated with firefighting facilities; and the costs of overtime payments will be invoiced by the JIRA to the exhibitor after the end of the session. Please be advised that invoices cannot be forwarded to other companies, such as contractors, for reasons of processing.
- (e) The sponsor and the operator of the exhibition accept no liability for any injury or damage of human bodies or properties caused by the use of the exhibition space by the exhibitors including exhibitor's employees and related parties, whatever the causes may be. The exhibitors shall be liable for any damages of the exhibition hall and its surrounding buildings and facilities caused by carelessness, etc. of their employees, related parties, agents, decorating companies, transportation companies, etc.
- (f) The booths are positioned so as to secure the evacuation routes in the hall and so as not to obscure the emergency exit sign lighting.
During the exhibition, we display in the hall the maps to indicate the location of the evacuation routes and the emergency exit sign lighting. Look at them in advance.
At the time of disaster or emergency, listen to the oral announcement and evacuate quickly. The exhibitor companies are encouraged to maintain in advance a high degree of preparedness for emergency action and communication, and thereby to secure the safety of clients, employees, and staff.

24. About compliance with laws and regulations

(a) Each exhibitor shall manage the labor service based on Labor Standards Law and Occupational Health and Safety Law in every working aspect.

(b) About the fair competition rule

The Fair Trade Council for Medical Equipment Business submitted a notice to Consumer Affairs Agency and the Fair Trade Commission based on Law for Preventing Unjustifiable Lagniappes and Misleading Representation. The notice concern the fair competition rule to be applied during the period of this exhibition. When you plan to distribute novelties, or to give tips to respondents to questionnaire, then you must comply with the following matters. (1) Novelties or tips must be equivalent to a small amount of money according to common-sense judgment. (2) Novelties must not be changeable with money. (3) You must behave along business ethical guidelines. (4) Your behavior must be free from any legal restrictions. Moreover, tips to respondents to questionnaire shall not exceed one thousand Japanese yen. Additionally, at exhibition sites attached to academic conferences, you must pay attention to the further detailed and concrete matters. Please be sure to be present at the orientation meetings for the exhibitors and ensure that you plan will comply with these matters.

(c) Prohibition of PR activities for companies

ITEM is one of exhibitions attached to academic conferences held for professionals in medicine, dentistry and pharmacology, and it is intended to promote academic improvement and advance. Please refrain from PR activities that are not in line with the above-mentioned concept, for example, promotion of science/technology or industry for general public, or advertisement of medical equipment.

25. Miscellaneous

(a) Exhibitors are requested not to leave their booth unattended during the exhibition.

(b) When leaving at closing time, exhibitors are requested to attend to the care of their exhibits, turning off the service entrance switch (distribution switchboard), and other necessary tasks.

(c) The exhibition secretariat will be located beside the hall entrance.

(d) Exhibitors should obtain permission from the staff of the booth concerned before entering another company's booth.

(e) The press must apply for prior permission to cover the event at reception and in certain instances follow instructions as given by the exhibition secretariat.

In addition, each company should inform the secretariat when there has been any specific request for media coverage.

26. Exhibition of Products Not Approved Under the Act on the Pharmaceuticals, Medical devices, etc.

For the Attention of All Exhibitors

Japan Medical Imaging and
Radiological Systems Industries Association
Exhibition Committee

Exhibition of Products Not Approved Under the Act on Securing Quality, Efficiency and Safety of Pharmaceuticals, medical devices, re-generative and cellular therapy products, gene therapy products, and cosmetics (the Act on the Pharmaceuticals, Medical devices, etc.)

In accordance with the guidance of the Ministry of Health, Labor and Welfare, products not approved under the Act on Pharmaceuticals, Medical devices, etc. may be exhibited only if they are recognized as contributing to the promotion of science, in strict compliance with the conditions below.

The Exhibition Committee would like to emphasize that exhibition will be refused in the event of any breach of these conditions.

1 The putative exhibitor must submit an Application for Exhibition to the chairperson of the conference. The company will be regarded as having made such a request only if the chairperson of the conference recognizes the product as contributing to the promotion of science.

2 In concrete terms, the exhibitor is requested to complete two forms, one copy of PAL Form 11: Application for Exhibition and one copy of PAL Form 12: Request for Exhibition (two copies in the case of imported items*), and submit these to the exhibition organizer by the deadline indicated in the Exhibition Guidelines. (* One copy is needed for customs clearance.)

Requests will be forwarded to the conference chairperson in a single batch, and the Request for Exhibition returned to each company as soon as it is approved. During the exhibition period, please disclose the forms upon request.

Please prepare the Application for Exhibition and Request for Exhibition in A4 size as attached forms. Also, a sample of a separate documentation for the Request for Exhibition is shown following PAL Form 11: Application for Exhibition for use as a reference. Name of applying company for exhibition shall be the Representative for the applying company.

3 Strict compliance with the following conditions is requested during exhibition.

(a) A notice must be displayed near the exhibit stating that it is a product not approved under the Act on Pharmaceuticals, Medical devices, etc. and that neither its sale nor presentation is permitted.

To unify the notices, we ask that you purchase the one produced by the Exhibition Committee. The diagram right shows the size of the notice, to be used as a basic rule. To accommodate small devices, PC and other equipment, however, we also accept sizes (ii) to (iv) shown below.

(i) A notice to be used, as a basic rule (diagram, right). A stand will not be attached.)

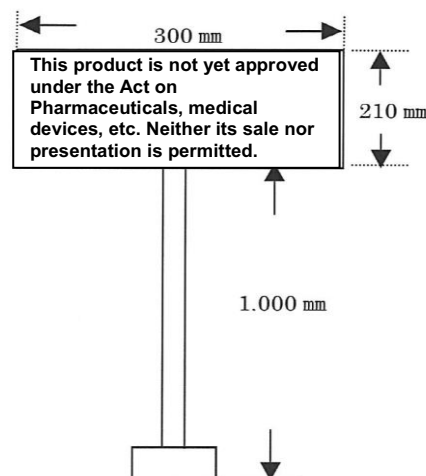

- (ii) For use with panel or mid-size devices (210 mm x 150 mm; stand-alone type)
- (iii) For tabletop display of small devices (150 mm x 105 mm, stand-alone type)
- (iv) Stickers for use with PCs and tablets (66 mm x 15 mm, a set of 3 stickers)

The price is 540 yen per notice for each size, but this does not include the cost of stand for notices for use with machinery.

An application form is Form 13.

One notice is required for each product not approved under the Act on Pharmaceuticals, Medical devices, etc.

- (b) Claims concerning method of manufacture, effect and efficacy, and performance must be precise and based on data from objectively performed testing or other similar source. They should avoid advertising-type material, and be restricted to scientific expressions. The same applies to exhibitions consisting solely of clinical photographs. (Please also be careful when producing descriptive panels.)
The following examples are acceptable.
 - (i) Research data to be presented at the conference involved.
 - (ii) Data evaluated in applications for approval under overseas pharmaceutical legislation.
 - (iii) Scientific data provided by the National Institute of Health Sciences, the Tokyo Metropolitan Industrial Technology Center, or the Japan Quality Assurance Organization. (This includes data provided by universities.)
 - (iv) Research data published as a paper in specialist scientific journals that possess paper review mechanisms.
In this case, the name of the journal concerned must be clearly stated in order to make clear the source of the data.
- (c) Related documentation and other materials may not be distributed.
However, it is acceptable to hand out reprints of research papers and similar material from scientific papers that have already been evaluated to doctors and others on request.
- (d) The proposed brand name may also be used, provided that this is solely for the purpose of the improvement and development of scientific research.
However, the distribution of prepaid cards or free gifts carrying the brand name is unacceptable unless it is directly connected to the improvement and development of scientific research.
- (e) Notes on exhibition
It is prohibited to carry out the same PR activities for non-approved products as for products that are already approved, under Article 68 of the Act on Pharmaceuticals, Medical devices, etc.
Examples of such actions include the following.
 - (i) Using amplifying devices (speakers) such as microphones or tape recorders to introduce non-approved products.
 - (ii) Using video or similar recordings other than those of conference presentations or reports to introduce non-approved products.
 - (iii) Displays using spotlight or similar means to make non-approved products more eye-catching than products that are already approved.
 - (iv) Material used on panels must be limited to scientific content. (Descriptions of features, etc. are not permitted.)
 - (v) Actions pursuant to the above.
- (f) After the exhibition closes, the product may not be sold or given away, but must be disposed of, sent back, or dealt with in another appropriate way.
However, this shall not apply should specific administrative procedures be undergone to permit use in treatment, change of use for the purpose of an application for approval, or storage pending expected early approval being obtained.

- 4 Should the exhibitor cancel the exhibition or approval be obtained after an application has been submitted, the exhibitor is requested **to notify the organizers prior to the opening of the exhibition** by submitting the Notification of Withdrawal of Application for Exhibition of Product Not Approved Under the Act on Pharmaceuticals, Medical devices, etc.

Address for submission of Application for Exhibition and Request for Exhibition

Sumitomo Fudosan Iidabashi Bldg. No.2 6F

2-2-23, Kouraku, Bunkyo-ku, Tokyo 112-0004, Japan

Attn: Exhibition Committee Secretariat, Japan Medical Imaging and Radiological Systems
Industries Association

Tel: 81-3-3816-3450. Fax: 81-3-3818-8920

Exhibition of Products Not Approved Under the Act on Pharmaceuticals, Medical devices, etc. (Detailed guidelines)

The Act on Pharmaceuticals, Medical devices, etc. prohibits advertising or publicity for products not approved under the law. As exhibition comes into the category of advertising and publicity, in principle non-approved products may not be exhibited. However, if the objective is to further the improvement of medical or scientific research or to promote its development, products may receive special permission for exhibition, based on the industry's voluntary management standards "Detailed guidelines concerning non-approved medical equipment and similar items" and solely subject to certain criteria.

The main conditions set out by these detailed guidelines are given below.

- 1 Types of Exhibition: Aimed at specialists in related fields, with the objective of improving and developing scientific research.
- 2 Organizers: Organizations consisting of scientists in related fields and which hold public conferences and other events with the objective of improving and developing scientific research.
- 3 Means of Exhibition:
 - (a) The product must display a notice stating that it is non-approved and may not be sold or given away (the method of displaying such a notice should be as consistent as possible)
 - (b) Claims concerning method of manufacture, effect and efficacy, and performance must be precise and based on data from objectively performed testing or other similar source. (They should avoid advertising-type material, and be restricted to scientific expressions.)
 - (c) Related documentation and other materials may not be distributed in principle. However, it is reasonable to hand out reprints of research papers and similar material from scientific papers that have already been evaluated to doctors and others on request.
(Catalogs are classified as advertising or publicity materials and may not be distributed.)
 - (d) The proposed brand name may also be used, provided that this is solely for the purpose of the improvement and development of scientific research.
(However, the distribution of prepaid cards or free gifts carrying the brand name is prohibited.)
 - (e) It is not permitted to carry out the same PR activities for non-approved products as for products that are already approved. (This means not introducing products by using microphones, speakers, or other amplifying devices, audiovisual equipment other than recordings of conference presentations or reports; or display methods that make non-approved products more eye-catching than products already approved.)

Exhibitors should be aware that partial modifications to existing products also result in their classification as non-approved products.

Should a problem arise owing to a breach of these conditions, this may result in grave inconvenience being caused not only to the chair of the conference, who has overall responsibility for the Exhibition, and the JIRA, which is responsible for the Exhibition itself, but also to the exhibitor. **We appreciate your cooperation in complying with the rules and enabling the progress of this Exhibition.**

27. Where to inquiry and submit documents (related to exhibition and required)

Exhibitors must submit all the required documents before the appropriate deadlines (including attached plans and other documentation found in separate EXCEL file).

Inquiry and submission (Forms 1, 2, 3, 4, 6, 7 and 8 shall be emailed.)

All the required forms are available by downloading from JIRA website (<http://www.jira-net.or.jp/e/index.htm>).

Please submit the documents in Excel sheet without any modification

Secretariat of the International Technical Exhibition of Japan Medical Imaging and Radiological Systems Industries Association (JIRA)

Address: Sumitomo Fudosan Iidabashi Bldg. No.2 6F
2-2-23, Kouraku, Bunkyo-ku, Tokyo 112-0004, Japan

Tel: 81-3-3816-3450. Fax: 81-3-3818-8920

E-mail : exhibit@jira-net.or.jp (submission)

Documents to be submitted	Form	Submission deadline
additional quantities of Registration/Entry Cards	(No form)	January 9, 2018 (Tue.)
Notification of decoration work and applications for name cards	Forms 1, 3	February 16, 2018 (Fri.)
Power supply application	Form 2	ditto
Notification of the number of vehicles used for load-in/out for booth without basic fittings	Form 4	ditto
Notification of the number of vehicles used for load-in/out for booth with basic fittings	Form 4	ditto
Notification of the use of anchor bolts	Form 6	ditto
List of exhibits (refer to ITEM2018 Exhibit Classification Table)	Form 7	ditto

Documents related to the products not approved under the Act on Pharmaceuticals, Medical devices, etc. (Submitted by mail)

Documents to be submitted	Form	Submission Deadline
Application for exhibition of product not approved under the Act on Pharmaceuticals, Medical devices, etc.	Form 11	February 16, 2018 (Fri.)
Description of product not approved under the Act on Pharmaceuticals, Medical devices, etc.	(No form)	ditto
Request for exhibition of product not approved under the Act on Pharmaceuticals, Medical devices, etc.	Form 12	ditto
Notification of withdrawal of application for exhibition of product not approved under the Act on Pharmaceuticals, Medical devices, etc.	Form 13	ditto
Application for notice board for exhibiting product not approved under the Act on Pharmaceuticals, Medical devices, etc.	Form 14	By before the opening of exhibition

■ **Booth without basic fittings (Submitted by mail)**

Documents to be submitted	# of copies	Submission Deadline
Booth interior plans (floor plan, elevation, birds-eye view)	2 ea. (No form)	February 16, 2018 (Fri.)

■ **Ceiling or roof width exceeding 90 cm (Submitted by mail)**

■ **In the case of Two-Story structure (Submitted by mail)**

Documents to be submitted	Form or # of copies	Submission Deadline
Application for Two-Story and Ceiling Structure	Form 8	February 16, 2018 (Fri.)
Each form which is mentioning in form 8	each 2 ea. (No form)	ditto

■ **Handling of communication devices (excluding wireless LAN devices [Wi-Fi, Bluetooth])**

Documents to be submitted	# of copies	Submission Deadline
Contents of demonstration, accessories to be used, etc.	1 ea. (No form)	February 16, 2018 (Fri.)

Event Name: International Technical Exhibition of Medical Imaging 2018
Temporary Telephone Line Application Form

Submission Deadline: Friday, March 9, 2018

Date Submitted: Month Day 2018

Booth / Room Name		Booth / Room Number	
Company Name			
Address			
Department in Charge		Name of Supervisor	
TEL		FAX	

◆ I would like to apply for a temporary telephone line as follows:

Analog line (telephone charges assessed separately, includes 1 telephone)	X	Line	8,000 yen (tax exclusive)
Cordless phone	X	Telephones	500 yen (tax exclusive)
Total (tax exclusive)			

◆ Please install the temporary telephone lines in the following locations (note the adjoining booths)

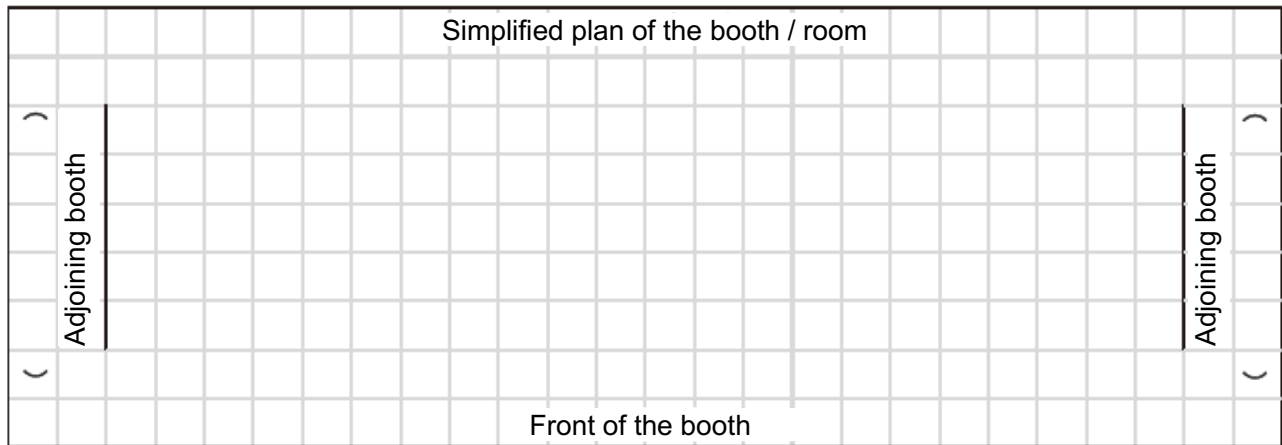

◆ Recipient for Temporary Telephone Line Invoices

Company Name		Department in Charge		Super visor	
Address					
TEL		FAX			

◆ If you wish to designate a date for the bank transfer, enter it here. (/)(Month/Day)

Inquiries Regarding the Application	TEL: 81-45-221-2183 FAX: 81-45-221-2184
	Pacifico Yokohama Exhibit Hall Operation Group Supervisors: Takashima / Terauchi Pacifico Yokohama Exhibition Hall 2F 1-1-1 Minato Mirai, Nishi-ku, Yokohama-shi, Kanagawa-ken 220-0012

Event Name: International Technical Exhibition of Medical Imaging 2018
Temporary FLET'S HIKARI circuit Application Form

Submission Deadline: Friday, March 9, 2018

Date Submitted: Month Day 2018

Booth / Room Name		Booth / Room Number	
Company Name			
Address			
Department in Charge		Name of Supervisor	
TEL		FAX	

◆ I would like to apply for a temporary FLET'S HIKARI circuit as follows:

FLET'S HIKARI NEXT and OCN optical access IP zero plan	x Circuit	¥95,000 (excluding tax)
FLET'S HIKARI NEXT and OCN optical access IP1 plan	x Circuit	¥119,500 (excluding tax)
FLET'S HIKARI NEXT and OCN optical access IP1 business plan	x Circuit	¥214,600 (excluding tax)
Wireless access point (WIFI) stand	Number of stands	¥9,000 (excluding tax)
		Total (tax exclusive)

◆ Please install the temporary FLET'S HIKARI circuit in the following locations (note the adjoining booths)

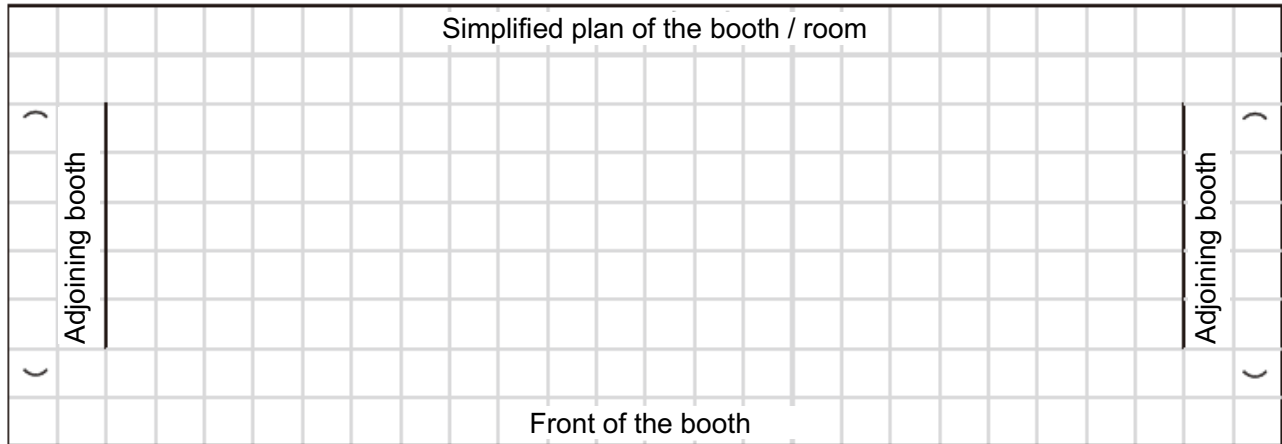

◆ Recipient for temporary FLET'S HIKARI circuit Invoices

Company Name		Department in Charge		Super visor	
Address					
TEL		FAX			

◆ If you wish to designate a date for the bank transfer, enter it here. (/)(Month/Day)

Inquiries Regarding the Application	TEL: 81-45-221-2183 FAX: 81-45-221-2184
	Pacifico Yokohama Exhibit Hall Operation Group Supervisors: Takashima / Terauchi Pacifico Yokohama Exhibition Hall 2F 1-1-1 Minato Mirai, Nishi-ku, Yokohama-shi, Kanagawa-ken 220-0012

Application for Exhibition International Technical Exhibition of Medical Imaging 2018

Date _____

To Chairperson Kuni Ohtomo
Japan Radiology Congress (JRC)

Name of applying company _____

Name of the Representative _____

Signature _____

Considering the item indicated below will contribute to the promotion of science, we hereby apply for its exhibition, with referential materials separately attached, in strict compliance with the Act on Pharmaceuticals, Medical devices, etc.

1. Exhibit (a product not approved under the Act on Pharmaceuticals, Medical devices, etc.)
New item or partially modified item (Please circle either) : New / Partially modified
Designation:
Description:
Quantity:

2. Reasons for exhibition
 - a) The item is presented at the meeting concerned.
 - b) The item has been newly developed, applying a newly introduced technology.
 - c) The item has been improved, using a newly introduced technology.
 - d) The item has been newly developed on the basis of a new principle.
 - e) The item has been improved on the basis of a new principle.
 - f) Other reason (Please specify _____)

3. Exhibition site: *Pacifico* Yokohama Exhibition Halls A (a part), B, C, and D

4. Exhibition dates: April 13 (Fri.): 10:00 (following the opening ceremony) – 17:00
 April 14 (Sat.): 9:30 – 17:00
 April 15 (Sun.): 9:30 – 15:00

Sample of separate documentation attached to the application for exhibition

Reasons for Exhibition (Sample)

1. Summary of the reasons for image quality improved by the introduction of a new technique,
 - a) A large volume of data is obtained over a short time by using continuous radiation, suppressing artifacts from body motion to yield more detailed images.
 - b) Application of high frequency inverter for generating high voltage X-ray produces stability at high voltage, which enables the provision of high quality images despite a short scan time.
2. Miscellaneous (documents demonstrating the features of the exhibits should be added if any.)

End

Request for Exhibition

Date _____

Kuni Ohtomo
Chairperson
Japan Radiology Congress (JRC)

Request for Exhibition at International Technical Exhibition of Medical Imaging 2018

After a deliberate investigation, the following item (1) that has not been approved under the Act on Pharmaceuticals, Medical devices, etc. has been judged to be in compliance with the objective of our association. We therefore request herein to exhibit the item at the exhibition under the conditions described in the section (2) and section (3) below.

(1) Item

Designation: _____
Description: _____
Quantity: _____

(2) Exhibition site and dates

Site: Pacifico Yokohama Exhibition Halls A (a part), B, C, and D
Dates: April 13 (Fri.): 10:00 (following the opening ceremony) – 17:00
April 14 (Sat.): 9:30 – 17:00
April 15 (Sun.): 9:30 – 15:00

(3) Conditions

- (a) It should be Indicate clearly that the item is not approved under the Act on Pharmaceuticals, Medical devices, etc. and that neither its sale nor presentation is permitted.
- (b) Claims concerning method of manufacture, effect and efficacy, and performance must be precise and based on data from objectively performed testing or other similar source.
- (c) In principle, related documentation and other materials may not be distributed.
- (d) After the exhibition closes, the item may not be sold or given away, but must be disposed of, sent back, or dealt with in another appropriate way.

Form 13

**Application for Notice Boards for Exhibiting Products not Approved
under the Act on Pharmaceuticals, Medical devices, etc.**

Date _____

To Japan Medical Imaging and
Radiological Systems Industries Association (JIRA)

Booth number _____

Company name _____

Address _____

Section _____

Person in charge _____

Phone _____

Facsimile _____

E mail _____

Submission deadline: February 16, 2018

We are pleased to submit an application as indicated below.

Type	Unit price (including tax)	Quality	Amount
(i) A nitice to be used, as a basic rule (300 x 210 mm, A stand will not be attached.)	¥540	PCS	¥
(ii) For use with panel or mid-size devices (210 mm x 150 mm; stand-alone type)	¥540	PCS	¥
(iii) For tabletop display of small devices (150 mm x105 mm, stand-alone type)	¥540	PCS	¥
(iv) Stickers for use with PCs and tablets (66 mm x 15 mm, a set of 3 stickers)	¥108	SET	¥
	Total	PCS	¥

Notification of Withdrawal of Application for Exhibition
of Product Not Approved under the Act on Pharmaceuticals, Medical devices, etc.

Date _____

To Chairperson Kuni Ohtomo
Japan Radiology Congress (JRC)

Name of applying company _____

Name of the Representative _____

Signature _____

We would like to withdraw the application for exhibition of the following product not approved under the Act on Pharmaceuticals, Medical devices, etc. because of

- our own circumstances
- approval obtained as follows:

Date of approval: _____

Number of approval: _____

Date of Application for Exhibition: _____

Description of Item: _____

Quantity: _____

End